

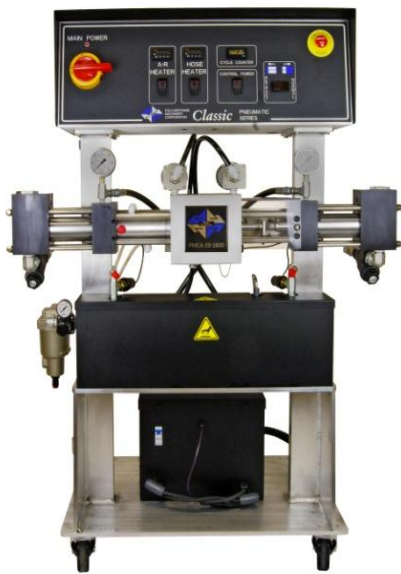

POLYURETHANE MACHINERY CORPORATION



PMCA-20 Proportioner Manual

**Pneumatic, Heated, Plural Component
Proportioner**

**For spraying Polyurethane Foam and
Coatings**

For Professional Use Only

**Not approved for use in
Explosive atmosphere locations**

Ref. # MN-06001

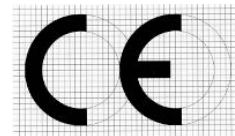

REVISION 2.0

Polyurethane Machinery Corp.

Headquarters: 1 Komo Drive, Lakewood NJ 08701

Manufacturing: 2 Komo Drive, Lakewood, NJ 08701

Phone: 732-415-4400

Fax: 732-364-4025

<http://www.polymac-usa.com>



Before installing the PMCA-20 Series Proportioner and start-up, carefully read all the technical and safety documentation included in this manual. Pay special attention to the information in order to know and understand the operation and the conditions of use of the PMCA-20 Series Proportioner. All of the information is aimed at improving user safety and avoiding possible breakdowns from the incorrect use of the PMCA-20 Series Proportioner.



PMCA-20 Manual

TABLE OF CONTENTS

WARRANTY	4
SAFETY AND HANDLING	6
CHARACTERISTICS	9
Principal Heating System	9
Hose Heating System	9
Double Acting Opposed Piston Metering Pumps	9
TECHNICAL SPECIFICATIONS	10
Electrical	10
Mechanical.....	10
DESCRIPTION	11
INSTALLATION	14
Heated Hose Installation	15
Transformer Settings	17
PROPORTIONER PURGING	19
DIGITAL TEMPERATURE CONTROLLER	21
START-UP	22
SHUT-DOWN	23
TROUBLESHOOTING	24
Heaters	25
Hose Heat.....	28
Pneumatic Drive System.....	31
Metering Pump Line.....	33
MAINTENANCE	36
Inlet Material Screens	36
Iso Pump Lube System.....	37
Metering Pump Line.....	37
Pump Base Service	38
Material Heater	39
REPLACEMENT KITS	41
DOUBLE ACTING PROPORTIONING PUMP DIAGRAM	46



PMCA-20 Manual

PART IDENTIFICATION	47
Pump Line Assembly	47
Air Motor Assembly	49
“A” Pump Assembly; Size 60 & 40	51
“R” Pump Assembly; Size 60 & 40	53
Piston Assembly; Size 60 & 40	55
Pumpbase Assembly	56
Pre Heater Assembly	57
Y-Strainer Assembly; “A” & “R” Side	59
Air Machine	60
Lube Bottle Components	65
Hoses	66
TECHNICAL SERVICE BULLETIN	68
MANUAL REVISIONS	71



PMCA-20 Manual

WARRANTY

Polyurethane Machinery Corporation (hereinafter “PMC”) provides this LIMITED WARRANTY (hereinafter “Warranty”) to the original purchaser (hereinafter “Customer”) covering this equipment and the original PMC manufactured accessories delivered with the equipment (hereinafter “Product”) against defects in material or workmanship of the Product (hereinafter “Defect” or “Defective”) for a period of one (1) year from the date of first purchase as shown on the original PMC invoice (hereinafter “Warranty Period”).

If during the Warranty Period under normal use, the Product is suspected by Customer to be Defective in material or workmanship, it is Customer’s responsibility to contact PMC and return the Product to PMC as directed by PMC, freight prepaid. If PMC determines that the Product is Defective and that such Defect is covered by this Warranty, PMC will credit Customer for the reasonable freight charges incurred by Customer in returning the Defective Product to PMC, and PMC (or its authorized agent) will, at PMC’s option, repair or replace the Product, subject to the following:

Original Invoice: The original invoice must be kept as proof of the date of first sale and the Product serial number. The Warranty does not cover any Product if the Original Invoice appears to have been modified or altered, or when the serial number on the Product appears to have been altered or defaced.

Product Maintenance: It is the Customer’s responsibility to maintain the Product properly. See your maintenance schedule and owner’s manual for details. The Warranty does not cover an improperly maintained Product.

Non-PMC Components and Accessories: Non-PMC manufactured components and accessories that are used in the operation of the Product are not covered by this Warranty. Such components and accessories shall be subject to the warranty offered to the Customer, if any, by the original manufacturer of such component or accessory.

Other Warranty Exclusions: The Warranty does not cover any Product that PMC determines has been damaged or fails to operate properly due to misuse, negligence, abuse, carelessness, neglect, or accident. By way of example only, this includes:

- Normal wear and tear.
- Improper or unauthorized installation, repair, alteration, adjustment or modification of the Product.
- Use of heating devices, pumping equipment, dispensers, or other parts or accessories with the Product that have not been approved or manufactured by PMC.
- Failure to follow the operating instructions and recommendations provided by PMC.
- Cosmetic damage.
- Fire, flood, “acts of God,” or other contingencies beyond the control of PMC.



PMCA-20 Manual

THE WARRANTY DESCRIBED HEREIN IS THE EXCLUSIVE REMEDY FOR THE CUSTOMER AND IS IN LIEU OF ALL OTHER WARRANTIES, EXPRESS, IMPLIED, STATUTORY OR OTHERWISE, AND THE IMPLIED WARRANTIES OF MERCHANTABILITY AND FITNESS FOR A PARTICULAR PURPOSE AND ALL OTHER WARRANTIES ARE HEREBY DISCLAIMED. TO THE FULLEST EXTENT PERMITTED BY LAW, PMC SHALL NOT BE RESPONSIBLE, WHETHER BASED IN CONTRACT, TORT (INCLUDING, WITHOUT LIMITATION, NEGLIGENCE), WARRANTY OR ANY OTHER LEGAL OR EQUITABLE GROUNDS, FOR ANY CONSEQUENTIAL, INDIRECT, INCIDENTAL, LOST PROFITS, SPECIAL, PUNITIVE OR EXEMPLARY DAMAGES, WHETHER TO PERSON OR PROPERTY, ARISING FROM OR RELATING TO THE PRODUCT, EVEN IF PMC HAS BEEN ADVISED OF THE POSSIBILITY OF SUCH LOSSES OR DAMAGES.

Non-Warranty Service by PMC: If PMC determines that the suspected Defect of the Product is not covered by this Warranty, disposition of the Product will be made pursuant to the terms and conditions of PMC's written estimate on a time and materials basis.

Continuing Warranty for Products Repaired or Replaced under Warranty: Following the repair or replacement of a Product covered by this Warranty, such Product will continue to be subject to the original Warranty for the remainder of original Warranty Period or for three (3) months from the repair or replacement date, whichever is longer.

No Rights Implied: Nothing in the sale, lease or rental of any Product by PMC shall be construed to grant any right, interest or license in or under any patent, trademark, copyright, trade secret or other proprietary right or material owned by anyone; nor does PMC encourage the infringement of same.

Exclusive Warranty: This writing is the final, complete, and exclusive expression of the Warranty covering the Product. Any statements made by PMC, its employees or agents that differ from the terms of this Warranty shall have no effect. It is expressly understood that Customer's acceptance of this Warranty, by performance or otherwise, is upon and subject solely to the terms and conditions hereof, and any additional or different terms and conditions proposed or expressed by Customer or anyone, whether in writing or otherwise, are null and void unless specifically agreed to in writing by an Officer of PMC.



PMCA-20 Manual

SAFETY AND HANDLING

This chapter contains important information on the safety, handling and use of your PMCA-20 Series Proportioner.



Before installing the PMCA-20 Series Proportioner and start-up, carefully read all the technical and safety documentation included in this manual. Pay special attention to the information to know and understand the operation and the conditions of use of the PMCA-20 Series Proportioner. All of the information is aimed at enhancing User Safety and avoiding possible breakdowns derived from the incorrect use of the PMCA-20 Series Proportioner.

WARNING! Presents information to alert of a situation that might cause serious injuries if the instructions are not followed.

CAUTION! Presents information that indicates how to avoid damage to the Proportioner or how to avoid a situation that could cause minor injuries.

NOTE! Is relevant information of a procedure being carried out.

Careful study of this manual will enable the operator to know the characteristics of the PMCA-20 Series Proportioner and the operating procedures. By following the instructions and recommendations contained herein, you will reduce the potential risk of accidents in the installation, use or maintenance of the PMCA-20 Series Proportioner; you will provide a better opportunity for incident-free operation for a longer time, greater output and the possibility of detecting and resolving problems fast and simply.

Keep this Operations Manual for future consultation of useful information at all times. If you lose this manual, ask for a new copy from your PMC authorized distributor or go online at our web site (www.polymac-usa.com).

The PMCA-20 Series Proportioner has been designed and built for the application of Polyurea chemical systems, polyurethane foam chemical systems and some two-component epoxy systems.

WARNING! The design and configuration of the PMCA-20 Series Proportioner does not allow its use in potentially explosive atmospheres or the pressure and temperature limits described in the technical specifications of this manual to be exceeded.



PMCA-20 Manual

Always use liquids and solvents that are compatible with the unit. If in doubt, consult your PMC authorized distributor.

When working with the PMCA-20 Series Proportioner, it is recommended that the operator wear suitable clothing and elements of personal protection, including, without limitation, gloves, protective goggles, safety footwear and face masks. Use breathing equipment when working with the PMCA-20 Series Proportioner in enclosed spaces or in areas with insufficient ventilation. The introduction and follow-up of safety measures must not be limited to those described in this manual. Before starting up the PMCA-20 Series Proportioner, a comprehensive analysis must be made of the risks derived from the products to be dispensed, the type of application and the working environment.



PMCA-20 Manual



To prevent possible injury caused by incorrect handling of the raw materials and solvents used in the process, carefully read the Material Safety Data Sheet (MSDS) provided by your supplier. Deal with waste caused according to current regulations.

Pour éviter toute blessure causée par une mauvaise manipulation des matières premières et les solvants utilisés dans le processus, veuillez lire attentivement la fiche signalétique (MSDS) fournies par votre fournisseur.
Traiter les déchets causés selon la réglementation en vigueur.



To avoid damage caused by the impact of pressurized fluids, do not open any connection or perform maintenance work on the components subject to pressure until the pressure has been completely eliminated.

Pour éviter les dommages causés par l'impact des fluides sous pression, ne pas ouvrir un lien ou d'effectuer des travaux d'entretien sur les éléments soumis à la pression jusqu'à ce que la pression a été complètement éliminé.



Use suitable protection when operating, maintaining or being present in the area where the equipment is functioning. This includes, but is not limited to, the use of protective goggles, gloves, shoes and safety clothing and breathing equipment.



Utiliser une protection appropriée utilisation, d'entretien ou d'être présents dans la région où le matériel fonctionne. Cela inclut, mais n'est pas limité à, l'utilisation de lunettes de protection, gants, chaussures et vêtements de sécurité et un équipement respiratoire.



The equipment includes components that reach high temperatures and can cause burns. Hot parts of the equipment must NOT be handled or touched until they have cooled completely.

L'équipement comprend des éléments qui atteignent des températures élevées et peuvent provoquer des brûlures. Les parties chaudes de l'équipement ne doit pas être manipulé ou touché jusqu'à ce qu'ils aient complètement refroidi.



To prevent serious injury through crushing or amputation, do not work with the equipment without the safety guards installed on the moving parts. Make sure that all the safety guards are correctly reinstalled at the end of the repair or maintenance work of the equipment.

L'équipement comprend des éléments qui atteignent des températures élevées et peuvent provoquer des brûlures. Les parties chaudes de l'équipement ne doit pas être manipulé ou touché jusqu'à ce qu'ils aient complètement refroidi.





PMCA-20 Manual

CHARACTERISTICS

The PMCA-20 Proportioner has been designed and built for the application of Polyurea chemical systems, polyurethane foam chemical systems and some specific two-component epoxy systems.

Principal Heating System

The Proportioner consists of one (1) independent Material Heater without internal seals. The Heater has six (6) Heating Elements rated 1250 watts each giving the Proportioner a total heat of 7500 watts and the necessary control and safety components for their precise operation. The Material Heater design allows a temperature differential (ΔT) of 53° F (12° C) and material application temperatures of up to 190° F (88 C) under normal ambient temperatures.

Hose Heating System

The system is designed with a 3 KVA (90 V) Isolation Transformer that enables effective heating of up to a total hose length of 310 ft (93 m). The system includes an innovative hose heating concept in which the continuous braid tinned-copper jacket is distributed evenly around the circumference of the hose providing a uniform heating watt density and precise control of the material application temperature. This hose heating element design is extremely resistant to fatigue failure.

100% circumferential coverage produces the most uniform distribution of heat available.

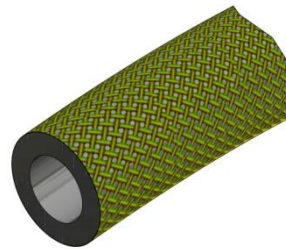

It is recommended to use PMC manufactured hose with all PMC Proportioners to get maximum Hose Heat operation.

Low Pressure Hoses - 2200 psi (152 Bar)

Part # MA-00014A

Part # MA-00014A-TC

Part # MA-00040A (10' whip, used for high pressure or low pressure)

High Pressure Hoses – 3500 psi (241 Bar)

Part # MA-00039A

Part # MA-00039A-TC

Double Acting Opposed Piston Metering Pumps

The opposed double acting Pump Line is driven by a double ended Pneumatic Cylinder. The in-line pump system with opposed piston pumps provides a constant volume and guarantees uniform pressures in both directions of pump movement.



PMCA-20 Manual

TECHNICAL SPECIFICATIONS

Electrical

Main Voltage.....1 x 208-230V, 50/60Hz
 Electrical Consumption(7500 watt Heater) 48 A @ 1 x 208-230V
 Material Heater Power..... 7.5 kW
 Hose Transformer Power 3 KVA (90 V)



CAUTION! Inside the console, is a Terminal Strip for connecting the main power (wire not supplied) to the PMCA-20 Series Proportioner. Use the appropriate AWG wire. This electrical connection must be made only by a qualified electrician.

Mechanical

Maximum working pressure (with 60 pumps) @ 100 psi (7 Bar) input..... 1600 psi (110 Bar)
 @ 110 psi (7.6 Bar) input 1800 psi (124 Bar)
 Use PMC Low Pressure Heated Hoses: MA-00014A and MA-00014A-TC

Maximum working pressure (with 40 pumps) @ 100 psi (7 Bar)2400 psi (165 Bar)
 Use PMC High Pressure Heated Hoses: MA-00039A and MA-00039A-TC

Maximum production @ ratio 1:1 (60 pumps)..... 18 lb/min (1.8 gals/min), 9kg/min (7.2 lpm)
 Maximum production @ ratio 1:1 (40 pumps)..... 12 lb/min (1.2gals/min), 6kg/min (2.4 lpm)
 Minimum production2 lb/min (1kg/min)
 Maximum hose length310 ft (93 m)
 Dimensions:.....30in W x 26in D x 45in H

NOTE! The PMCA Series is designed to be used with a PMC Spray Gun (3500 PSI, 241 Bar) or equivalent that is rated to the maximum pressure rating of the model being used.



PMCA-20 Manual

DESCRIPTION

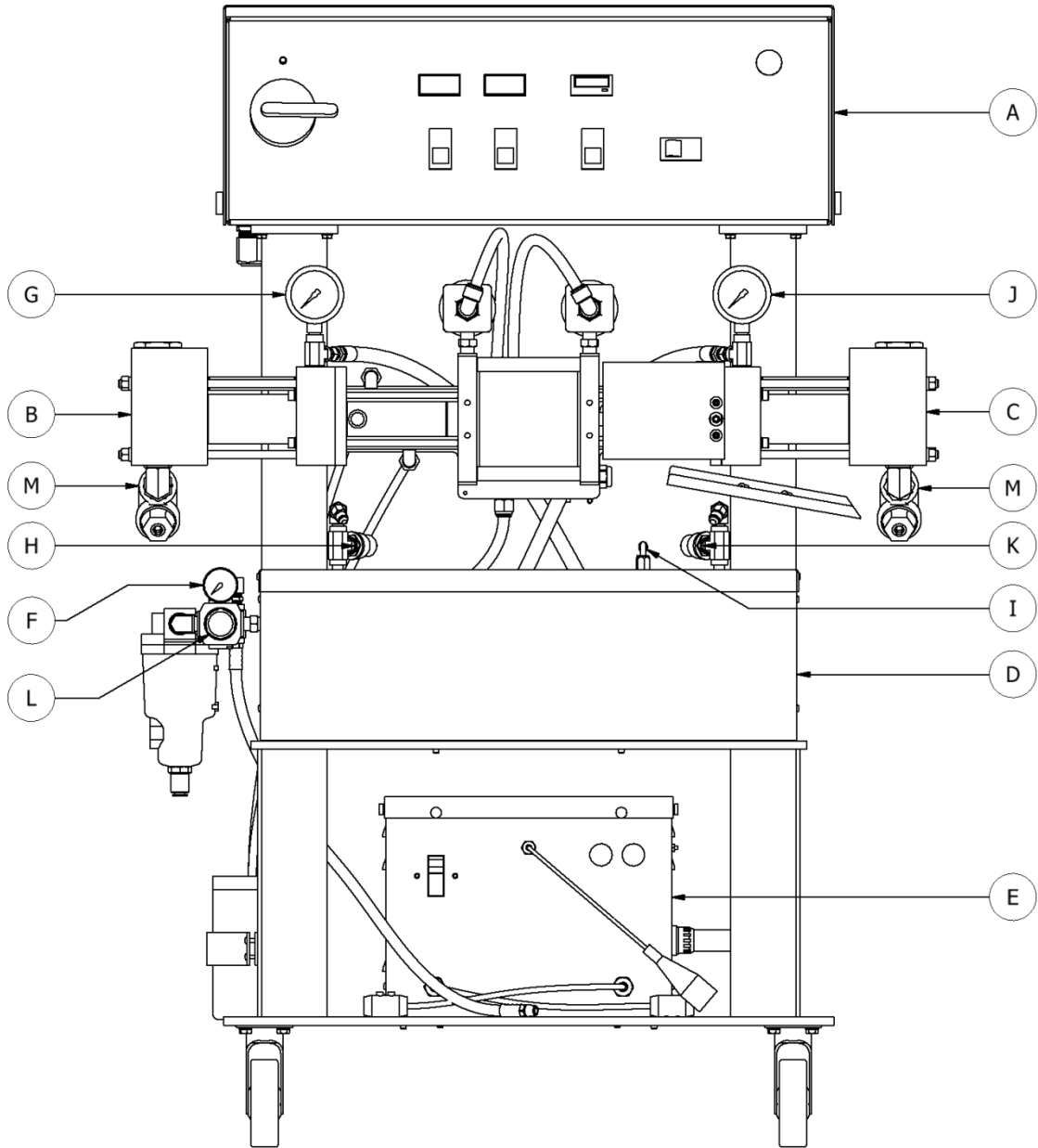

PMCA-20



PMCA-20 Manual

A. Control Panel

Controls and regulates the operation of the PMCA-20 Series Proportioner.

B. Isocyanate (Iso "A") Metering Pump

Meters the Isocyanate material.

C. Polyol (Poly "R") Metering Pump

Meters the Polyol material.

D. Heater

Heats the incoming chemical to a temperature set by the operator.

E. Hose Heating Transformer

Supplies the required voltage for material Heated Hoses.

F. Pneumatic Pressure Gauge

Indicates the pressure in the Pneumatic Drive System.

G. Isocyanate (Iso "A") Pressure Gauge

Indicates the pressure in the Isocyanate system.

H. Isocyanate (Iso "A") Safety Pressure Switch

Disables the pump circuit in the event of excessive pressure in the Isocyanate system.

I. Heater Thermocouple

Provides temperature information of the chemical to its Temperature Controller.

J. Polyol (Poly "R") Pressure Gauge

Indicates the pressure in the Polyol system.

K. Polyol (Poly "R") Safety Pressure Switch

Disables the pump circuit in the event of excessive pressure in the Polyol system.

L. Pneumatic Pressure Control

Allows the pressure of the pneumatic system to be increased or decreased. Turn clockwise to increase the pressure and counterclockwise to decrease. To pressure up the machine the NORMAL Pump Switch position must be selected.

M. Inlet Material Strainer

Filters (60 mesh) material from bulk supply.



PMCA-20 Manual

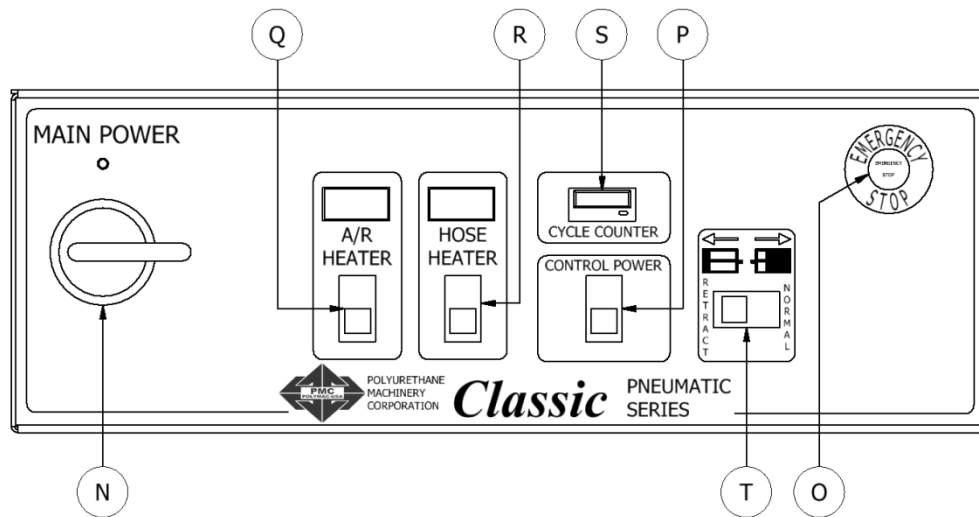

Control Panel

N. Main Power

Turns ON and OFF main power to the control panel. It must be turned ON for any operation to be performed with the unit. When turned ON, the red pilot will light.

O. Emergency Stop

Interrupts complete PMCA-20 Series control power circuit thus allowing NO power to the Heater, Hose or control system.

P. Control Power

The Control Power Switch only controls the 24 Volt DC necessary for any proportioner functions to operate. In the on position the temperature controllers will display ambient temperature and the main machine display will illuminate.

Q. Heater Controller Switch

Turns ON and OFF power to the Heaters. See detailed Temperature Controller instructions.

R. Hose Heater Control Switch

Automatically controls the Hose Heater only when using the TSU (Temperature Sensing Unit) probe.

S. Cycle Counter

Used to calculate the amount of chemical processed.

T. Pump Switch

Off - Removes power from the pump circuit. The red directional indicator lights will not be lit.

Normal - Activates the normal operation of the machine. When the switch is ON, the red directional light corresponding to the stroke direction will light.

Retract - Sets the Piston Rod of the Iso (A) metering pump to the retract position and prevents the crystallization of Iso (A) on the Piston Rod.



PMCA-20 Manual

INSTALLATION



WARNING! Use suitable protection and follow the recommendations in the Safety Information enclosed and provided by material suppliers when installing or working with the proportioner.

Inside the console is a Terminal Strip for connecting the incoming power cable (not supplied). Use appropriate AWG wire. The electrical connection of the proportioner must be carried out by a qualified electrician.

NOTE! To ensure the PMCA-20 Series Proportioner works correctly, the electrical supply must meet the specifications indicated on the Serial Number Placard affixed to the Electric Console.

CAUTION! Make sure the power cable is disconnected from the main power source before connecting to the Terminal Strip in the Console.

1 phase x (208- 230 Volt)

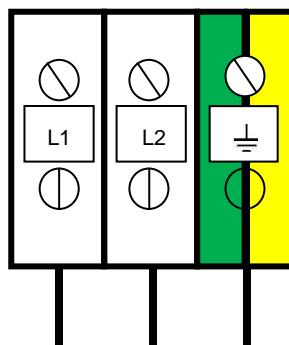

Follow the recommended procedure in the indicated order to install the proportioner:

1. Insert the main power cable by passing it through the strain relief at the bottom of the Electrical Console and connect as shown in the above diagram.
2. Fill the Lube Reservoir (plastic bottle) with PMC pump lube or equivalent. It is not necessary to prime the system when using size 60 pumps. It is recommended to prime the lube system when using size 40 pumps.



PMCA-20 Manual

Heated Hose Installation

CAUTION! The material delivery Heated Hoses are color coded Red and Blue allowing the user to recognize them. The Red corresponds to the Isocyanate (Iso “A”) and the Blue to the Polyol (Poly “R”). To avoid connection errors the Coupling Connections of the Iso “A” and Poly “R” Heated Hoses are also different sizes, which makes it difficult to swap connections.

NOTE! The material delivery Heated Hoses are capped at the ends to prevent absorbing moisture. Do not remove caps until the Heated Hoses are going to be installed on the proportioner.

1. Lay out all the Heated Hose assemblies end to end aligning the Iso (Red) and Poly (Blue) and connect the respective Coupling Connections using the appropriate sized open-end wrench after ensuring Heated Hose assemblies lay flat.

CAUTION! Take care to not cross-thread or over-tighten the Coupling Connections. Thread sealant tape or compound is not required for this tapered seat Coupling Connections.

2. Connect the material Heated Hoses to the outlets of the respective Heater connections i.e. Iso “A” Heated Hose to the Iso “A” Heater connection and the Poly “R” Heated Hose to the Poly “R” Heater connection ensuring the Heated Hose assemblies lay flat.
3. Connect Air Hose Coupling Connections.
4. Connect the Heated Hose power wires to the “Fast-Lock” Connector coming from the Hose Heat Transformer as follows:
 - a. Loosen the Socket Head Set Screw to allow insertion of the Heated Hose electrical wire Terminal.
 - b. Insert the Terminal into the “Fast-Lock” Connector Body.
 - c. Securely tighten the Socket Head Set Screw.

NOTE! Install electrical tape around Connector Body.

FAST-LOCK CONNECTION
PART # KT-00029A

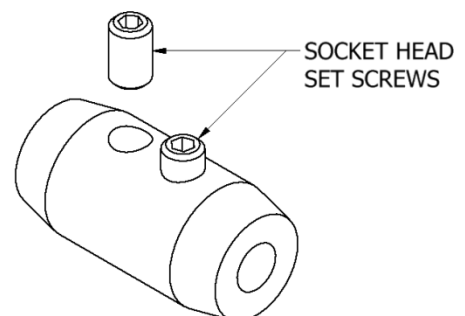



PMCA-20 Manual

NOTE! A good practice is to add some dielectric grease (Permatex 67VR or equivalent) to the outside of the Terminal prior to insertion.

Repeat the above steps to connect the “Fast-Lock” Connectors that you will find on all Heated Hose power wire. NOTE: All PMC heated hose wire is # 6 AWG.

CAUTION! Ensure the proper mechanical and electrical connections of the Heated Hoses are made to avoid possible material leakage and hose heat problems.

5. It is recommended the TSU be installed between the last section of Heated Hose and the Gun Whip. Carefully straighten the sensing wire, inserting it in the Iso “A” Heated Hose and tighten fluid fittings with appropriate sized open-end wrenches.

CAUTION! To protect the TSU sensor, you must pay special attention not to kink or excessively bend the Heated Hoses. Do not coil the Heated Hoses with a diameter of less than 4 feet.

CAUTION! Connecting the TSU between the first and second section of Heated Hose results in the TSU sensing the material temperature exiting the Heater and not the inside of the Heated Hose near the Spray Gun.

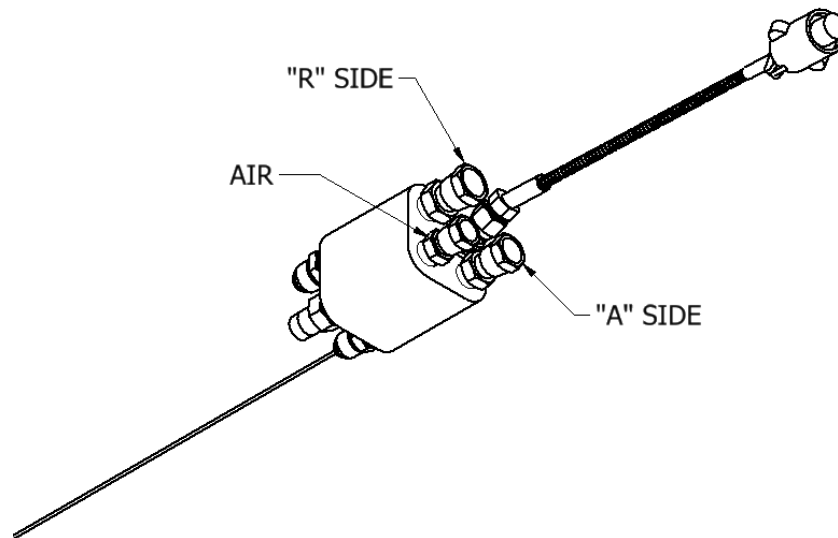

Temperature Sensing Unit
(TSU) Part # EL-51A-4
Replacement Sensor Part # EL-51A-2



PMCA-20 Manual

Transformer Settings

The Hose Heat Transformer offers the ability of connecting to different output voltages depending on the total length of the Heated Hose in use, maximizing the heating ability of the Heated Hose. The factory setting is 18 volts for use with 60 feet of Heated Hose. Before starting the proportioner, ensure the setting matches the Heated Hose length installed. If Heated Hose sections are added or removed, the Tap setting should be changed to a setting which will limit the maximum amperage in the Heated Hose to 52 amps. The suggested settings are tabled below:

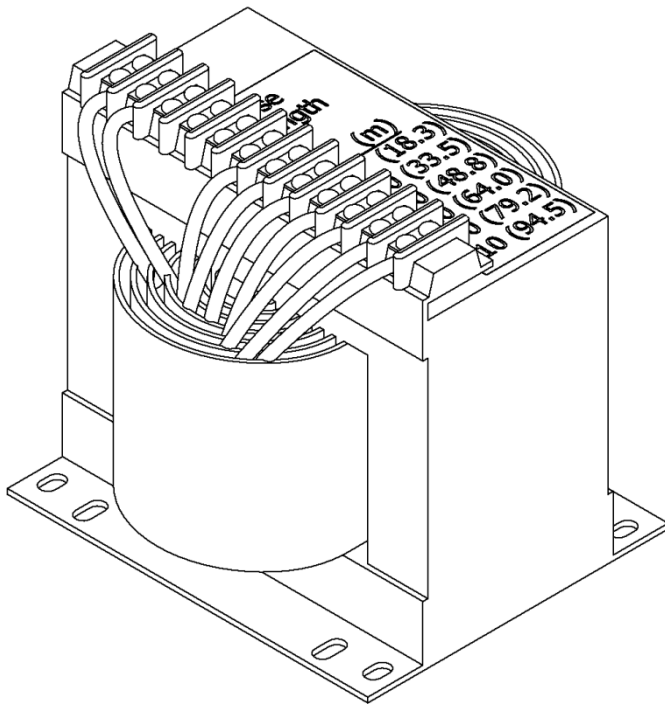

Tap	Feet	Meters
90v	310	94.5
75v	260	79.5
60v	210	64.0
45v	160	48.8
30v	110	33.5
18v	60	18.3

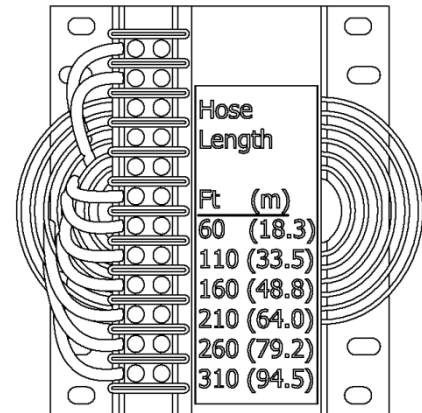

6. Ensure the Manual Valves are CLOSED and connect the Coupling Block to the Heated Gun Whip.

CAUTION! Excessive force closing or opening the Manual Valves may result in damage to the Manual Valves and/or Coupling Block.



PMCA-20 Manual

7. Connect the Transfer Pump/Heated Hose Assemblies air supply and air dryer systems as required. Review the Installation Instructions for each to ensure proper set-up and operation.
8. Install the Material Transfer Pumps as follows:

WARNING! If Transfer Pumps have been previously used, pay special attention to connect each Pump to “its” specific material. Inadvertently changing the Transfer Pumps will cause a chemical reaction rendering them useless.

NOTE! Placing a tape of the same color as of the Material Delivery Hoses (red for the Iso “A”, blue for the Poly “R”) on each Transfer Pump would be a good method for minimizing errors in connection.

- a. Make sure that the Inlet Valves on the Proportioner are closed.
- b. Connect one end of the Polyol “R” Material Delivery Hose ($\frac{3}{4}$ ” thread) to the proportioner Polyol “R” Inlet Valve and the other end to the Polyol “R” Transfer Pump.
- c. Connect one end of the Iso “A” Material Delivery Hose ($\frac{1}{2}$ ” thread) to the proportioner Iso “A” Inlet Valve and the other end to the Iso “A” Transfer Pump.
- d. Connect the air hose to the Transfer Pumps after ensuring each Transfer Pump Shut-Off Valve is CLOSED.

NOTE! To avoid errors in connection, the Coupling connections of the Iso “A” and Poly “R” Material Delivery Hoses are different sizes, making it difficult to swap connections.

CAUTION! Ground the Transfer Pump as recommended by the material supplier. The movement of product inside the Hoses can cause static electricity and produce electrical discharges.

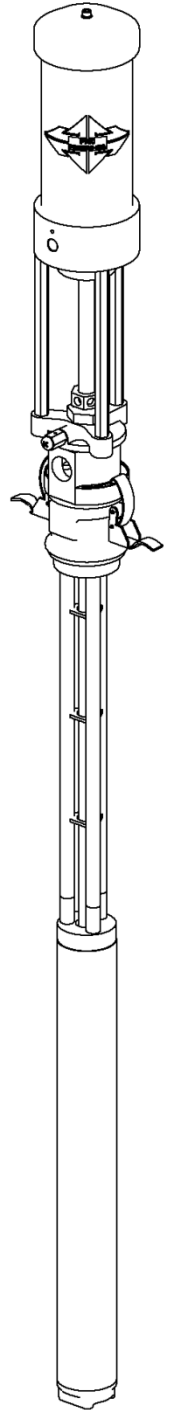



PMCA-20 Manual

PROPORTIONER PURGING



CAUTION! Use suitable Personal Protection Equipment (PPE)



CAUTION! Follow the recommendations in the Safety Information provided by product suppliers when installing or working with the unit.

NOTE! Before using the Proportioner it is necessary to purge the entire system, including Heated Hoses of mineral oil left over from Quality Control testing and air. The following procedure is also followed to purge air entrapped by running out of material in the supply Drum/Reservoirs resulting in a significant indicated material pressure imbalance as indicated by the Pressure Gauges and sprayed material.

1. Ensure the following before proceeding:
 - a. Air supply to Transfer Pumps is 90 - 110 psi (6.2 - 7.6 Bar)
 - b. Proportioner Inlet Valves are CLOSED.
 - c. All connections are tight.
 - d. Material should be stored to the material suppliers' recommended temperatures.
2. Slowly OPEN the Poly "R" Transfer Pump Air Shut-Off Valve allowing Pump to cycle slowly as it fills the Material Delivery Hose to the Proportioner. Check for leaks.
3. OPEN Poly "R" Coupling Block Manual Valve over a waste container.
4. Slowly OPEN Proportioner Poly "R" Inlet Valve allowing Transfer Pump to move material through the system. When all spitting of air stops and all traces of mineral oil have disappeared, CLOSE Poly "R" Coupling Block Manual Valve.
5. Clean Coupling Block.
6. Repeat steps 2 to 4 for Iso "A" side.

CAUTION! Properly dispose of all waste chemicals in accordance with all applicable local, state and federal codes.

7. Turn Pneumatic Pressure Control (L, page 12) full COUNTERCLOCKWISE.
8. Attach air supply to the water separator.
9. Turn on compressor.



PMCA-20 Manual

10. Turn ON Main Power (N, page 13). Red pilot will light.
11. Turn ON Control Power (P, page 13). Red pilot will light.
12. Set Pump Switch (T, page 13) to NORMAL. Turn Pneumatic Pressure Control CLOCKWISE increasing **material pressure** to 400 psi. Both Material Pressure Gauges (G, J, page 12) should read the same. Check all Heated Hose Coupling connections for leakage.
13. Check the TSU for leaks and that all “Fast-Lock” connections are tight and electrical tape is installed over their set screws.
14. Bundle all Heated Hose Connections ensuring no TSU Cable or Air Hose kinks. Wrap with Electrical Tape to securely hold all components in place and minimize places for bundle to snag onto job site protrusions.







PMCA-20 Manual

DIGITAL TEMPERATURE CONTROLLER

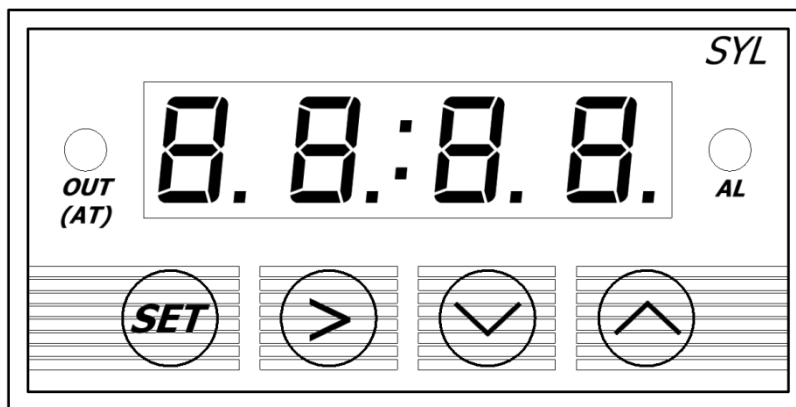
The PMCA-20 Series has two (2) Digital Temperature Controllers to manage the temperatures for the Primary Heater and the Heated Hose. The Hose Heater Controller is programmed different from the heater Controllers and therefore not interchangeable with them.

WARNING! Do not turn the Temperature Controllers ON until the Proportioner Purging procedure is complete and the Primary Heaters and Heated Hoses are filled with material.



1. Ensure Main Power is ON, Control Power is ON.
2. Press and release  or  button. The display will flash and indicate its current set point.
3. Press and hold the  or  to increase or decrease the material temperature set-point to the desired value as determined by the material supplier or application conditions.
4. Once the set point is entered the controller will go back to ambient temperature on its own (5-8 seconds).

WARNING! The Controllers are factory programmed and are not field re-programmable. If a problem is encountered, contact your PMC authorized distributor. Do not attempt to change any of the programmed parameters. Do not substitute a Controller from an alternate supplier as its use may result in equipment damage and/or bodily injury.

NOTE! The Temperature Controller normally displays the actual material temperature.



PMCA-20 Manual

START-UP

NOTE! Follow the recommended procedures in the order shown.

CAUTION! The Start-up procedures assume that all of steps in Proportioner purging have been performed and no problems found.

1. Check the condition of the DOP in the Iso “A” Lube Reservoir. Replace the DOP if you see significant changes in the color or signs of solidification. Ensure inside of Reservoir is wiped clean.
2. Make sure the materials have been stored at the manufacturer’s recommended temperature. Ask your material supplier for information (Material Data Sheet) on the minimum storage temperature.
3. Connect air supply to the two Transfer Pumps and ensure Air Valves are in the full OPEN position. OPEN both Proportioner Material Inlet Ball Valves.

CAUTION! Remove all Heated Hose sections from coiled storage and lay flat to eliminate heat build-up and possible Heated Hose failure.

4. Turn ON Main Power.
5. Turn on the air supply.
6. Turn ON Control Power.
7. Turn ON Hose and confirm the material set-point temperature is as recommended by the material supplier or application conditions.

CAUTION! To avoid excessive pressure in the Proportioner, wait for the Hose Heater to reach its set-point temperature before continuing.

8. Turn ON the Primary Heater and confirm material set-point temperature as required by the material supplier or application conditions has been reached.
9. Set Pump Switch to NORMAL. One of the Directional Indicator Lights will light indicating Metering Pump direction and the Metering Pump Shafts will begin to move.
 - a. The Material Pressure Gauges should be approximately equal and remain constant throughout Metering Pump cycle. If not, refer to Trouble Shooting section.
 - b. Directional Indicator Lights must indicate Metering Pump direction when Pump Switch is in the NORMAL position. If not, refer to Trouble Shooting section.
10. Using the Pneumatic Pressure Control (air regulator), adjust to the required stall pressure^① and check each Material Pressure Gauge.
11. Y strainer screens on the inlet of each pump should be checked once per week during start up.
12. Proceed with Installation and Start-up of the Spray Gun.

^① Stall pressure: When materials are at recommended application temperature and Metering Pumps are pressurized but not moving. This pressure is normally 100 – 200 psi (6.9 – 13.8 bar) greater than the developed spray pressure as recommended by the material supplier.



PMCA-20 Manual

SHUT-DOWN

Follow the recommended procedure in the indicated order for Proportioner temporary shut-down such as **lunch breaks**.

1. Set Pump Switch to OFF position.
2. Turn the Heater OFF. Hose Heater should remain ON. Never leave Proportioner ON if unattended.
3. CLOSE Spray Gun Manual Valves.

CAUTION! Excessive force opening or closing the Manual Valves may result in damage to the Manual Valves and/or Coupling Block.

Follow the recommended procedure in the indicated order for Proportioner shut-down when **work is stopped for the day**.

1. Set the Pump Switch to RETRACT.
2. Spray off the application surface until Material Pressure Gauges readings begin to fall.

CAUTION! To avoid possible Proportioning Pump Seal weepage, and moisture vapor drive into the Heated Hoses, the system pressure should not be reduced to zero. It is recommended to lower the system pressure to a minimum of 400 psi (27.6 Bar)

3. CLOSE the Spray Gun Coupling Block Manual Valves.

CAUTION! Excessive force opening or closing the Manual Valves may result in damage to the Manual Valves and/or Coupling Block.

4. Turn OFF the Heater and Hose Heater.
5. Turn OFF the Control Power.
6. Turn OFF the Main Power.
7. Disconnect the air supply to the two Transfer Pumps and CLOSE the Proportioner Material Inlet Valves.



PMCA-20 Manual

TROUBLESHOOTING

The PMCA-20 Series proportioner has been designed and built to withstand severe working conditions with a high degree of reliability, provided that it is used in a suitable application by a properly trained operator. This chapter contains information on possible faults that may interrupt the operation of the PMCA-20 Series. The information provided will serve as a guideline to detect and resolve problems. In any case, feel free to contact your PMC authorized distributor where a qualified technician will advise you.

CAUTION! All repairs performed by unqualified personnel or the use of spares other than originals may cause damage to the unit and put the operator at risk.



To prevent possible injury caused by incorrect handling of the raw materials and solvents used in the process, carefully read the Material Safety Data Sheet (MSDS) provided by your supplier. Deal with waste caused according to current regulations.

Pour éviter toute blessure causée par une mauvaise manipulation des matières premières et les solvants utilisés dans le processus, veuillez lire attentivement la fiche signalétique (MSDS) fournies par votre fournisseur.

Traiter les déchets causés selon la réglementation en vigueur.



To avoid damage caused by the impact of pressurized fluids, do not open any connection or perform maintenance work on the components subject to pressure until the pressure has been completely eliminated.

Pour éviter les dommages causés par l'impact des fluides sous pression, ne pas ouvrir un lien ou d'effectuer des travaux d'entretien sur les éléments soumis à la pression jusqu'à ce que la pression a été complètement éliminé.



Use suitable protection when operating, maintaining or being present in the area where the equipment is functioning. This includes, but is not limited to, the use of protective goggles, gloves, shoes and safety clothing and breathing equipment.



Utiliser une protection appropriée utilisation, d'entretien ou d'être présents dans la région où le matériel fonctionne. Cela inclut, mais n'est pas limité à, l'utilisation de lunettes de protection, gants, chaussures et vêtements de sécurité et un équipement respiratoire.



The equipment includes components that reach high temperatures and can cause burns. Hot parts of the equipment must NOT be handled or touched until they have cooled completely.

L'équipement comprend des éléments qui atteignent des températures élevées et peuvent provoquer des brûlures. Les parties chaudes de l'équipement ne doit pas être manipulé ou touché jusqu'à ce qu'ils aient complètement refroidi.



To prevent serious injury through crushing or amputation, do not work with the equipment without the safety guards installed on the moving parts. Make sure that all the safety guards are correctly reinstalled at the end of the repair or maintenance work of the equipment.

L'équipement comprend des éléments qui atteignent des températures élevées et peuvent provoquer des brûlures. Les parties chaudes de l'équipement ne doit pas être manipulé ou touché jusqu'à ce qu'ils aient complètement refroidi.



PMCA-20 Manual

Heaters

WARNING! Before troubleshooting make sure the Main Power Switch is OFF and incoming power is locked OFF. NEVER access the inside of the Control Panel with the Proportioner power supply ON. The Heaters are components that reach high temperatures; you must wait until they cool before handling.

NOTE! The Thermal Limit Switch is a safety switch in contact with the Heater body. If the surface temperature exceeds 225° F (107° C) the Limit Switch will shut off the Heater power. The Limit Switch will not reset until the temperature in the Heater is below 190° F (88° C).

Follow the recommended procedure in the indicated order to solve the problem and avoid unnecessary repairs. Make sure all Switches are in the correct position and Indicator Lights ON before determining the existence of a fault.

WARNING! Before proceeding with any troubleshooting that requires power up of unit, ensure all testing is performed by a qualified electrician.

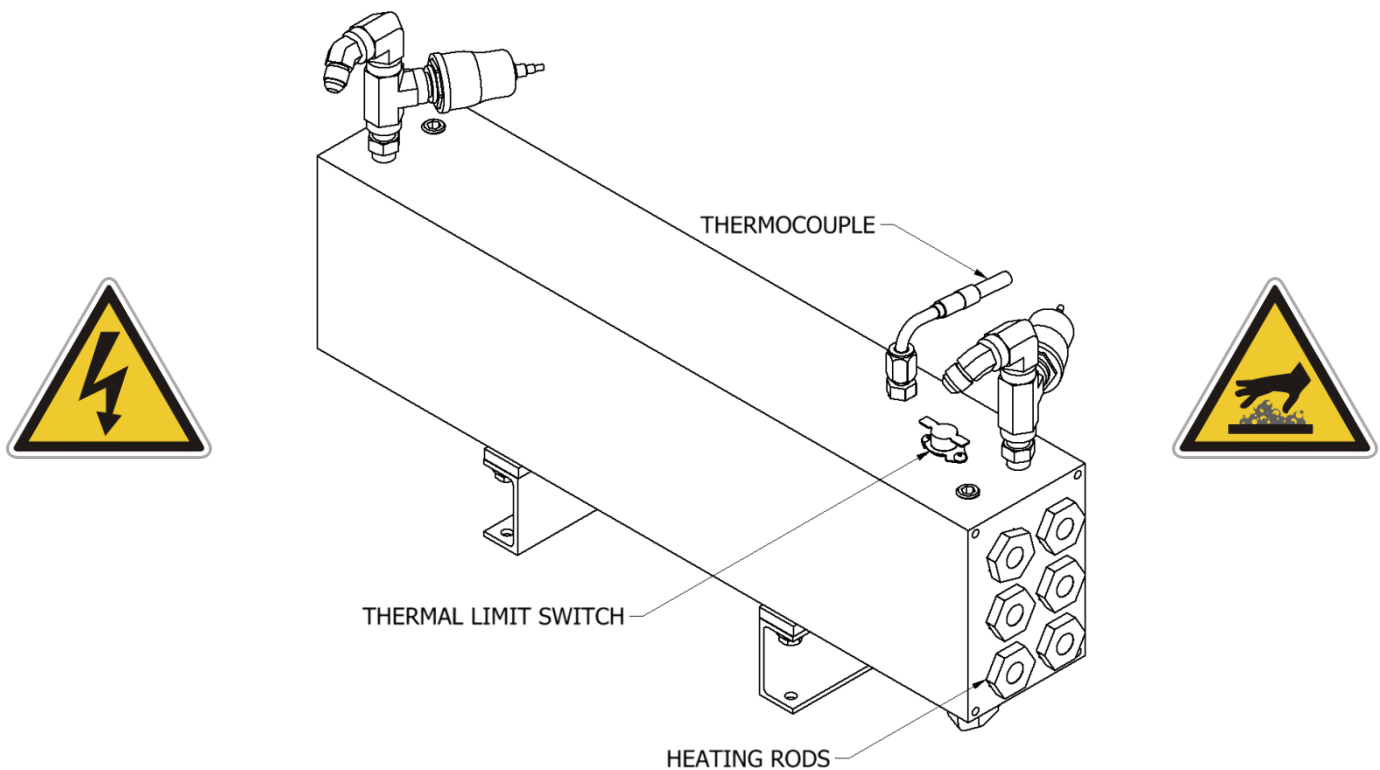



PMCA-20 Manual

PROBLEM

Primary heater does not heat and the display on the controller shows ambient temperature.

SOLUTIONS

1. Check that the light on the OFF/ON switch is lit when the heater is turned on, if not replace the switch.

If the light is on move to the next step.

1. Check the heater breaker in the main console, reset the breaker, if it continues to trip, wrap an amp clamp around one of the wires coming off the breaker if it does not exceed the rating of the breaker, the breaker needs to be replaced. If the breaker draws more than its rating the most likely cause is that one or more of the 1250 watt fire rods is shorted. Remove the heater cover, disconnect the wires and check each rod for resistance.

If the breaker is not tripped move on to the next step.

2. Open the console top and locate the solid state relay for the heater, looking over the console top from the front of the machine, it is the relay to the left. With the heater on and there is a LED light lit on the relay take a volt meter that is set on AC volts and measure across position L1 and L2 (heavy wires). With the relay functioning properly you should have a 1 volt reading, if you have a 208-230 volt reading, the relay has malfunctioned and needs to be replaced. If the AC voltage reads zero remove the pre-heater cover and look for loose or broken wires.

If there is no LED light on the solid state relay move to the next step.

3. With a DC volt meter read across position A1 and A2 on the solid state relay (smaller wires) if you have a reading of 4-6 volts DC replace the solid state relay.

If there is no DC voltage to the relay move to the next step.

4. Using a DC volt meter measure across position 9 and 10 on the back of the heater controller this is the output of the controller and sends power to the solid state relay, your reading will be 4-6 volts DC if there is no reading check to make sure that the set temperature of the controller is above the actual temperature reading on the controller. Before replacing the controller read across position 1 and 2 to make sure that the controller is powered up, your reading will be 208 to 230 volts AC. If no voltage is present check for loose wires or a malfunction of the heater circuit breaker.

If there is power in and out of the controller move to the next step.

5. Remove the heater top and check the over temperature limit switch for loose wires, if the wires are secure take a continuity reading across the switch.

If the switch is open or has no continuity replace the switch.



PMCA-20 Manual

PROBLEM

B -Primary heater does not heat and the display on the controller shows an error message.

SOLUTIONS

1. Check position 6 and 7 on the heater controller for loose wires.

If the wires are tight move to the next step.

2. Remove the heater cover and check that the thermocouple wires are secure to the harness going up to the controller.

If there are no loose connections replace the thermocouple.

PROBLEM

Primary heater controller shows excessive temperature and the circuit has turned off.

CAUTION! The heater must be allowed to cool down before continuing.

SOLUTIONS

1. Set the controller set point at least 20 degrees lower than the temperature shown on the controller. Briefly turn on the heater and look for the LED light on the solid state relay to be on.

If the light is on replace the controller.

If the light is off replace the solid state relay.

PROBLEM

Primary heater Temperature drops excessively while spraying.

SOLUTIONS

1. Temperature of the chemical in the containers is too cold.
2. Exceeding the flow rate specification of the machine.
3. **Disconnect power to the machine.**
 - a. One or more of the fire rods in the heater have malfunctioned. Remove the heater cover and take a resistance reading across the wires, **all the rods wired together should read 6.5 ohms**. If you have a higher reading than one or more of the rods are not working. Disconnect the wires and read each rod resistance, **each one should read 39.0 ohms**. Replace the damaged rod(s).
 - b. Installing a smaller mixing chamber in the gun may allow you to spray until a new rod(s) are installed.



PMCA-20 Manual

Hose Heat

CAUTION! All electrical testing must be done by a qualified electrician.

PROBLEM

Heated hose does not heat and the display on the controller shows ambient temperature.

SOLUTIONS

1. Check that the light on the OFF/ON switch is lit when the heater is turned on, if not replace the switch.

If the light is on move on to the next step.

2. Check the Hose Heat breaker in the main console. If the breaker continues to trip, reset it and wrap an amp clamp around one of the wires coming off the breaker. If it does not draw more than the rated value of the breaker, the breaker needs to be replaced.

If the breaker is not tripped move on to the next step.

3. Check the circuit breaker mounted on the transformer. If the breaker continues to trip, reset it and wrap an amp clamp around one of the wires from the transformer going to the heated hose. If it does not draw more than the rated value of the breaker, the breaker needs to be replaced.

If the breaker exceeds the rated value move on to the next step.

4. Check that the tap setting on the transformer is set for the proper hose length.

If it is set correctly move to the next step.

5. Using a voltmeter set on AC volts, and the hose circuit turned on, measure across the two leads coming out of the transformer that are connected to the "A" and "R" hose. If you are reading voltage (your volt reading will vary depending on what tap setting is used) most likely the problem is in the heated hose. Either a connector has come loose or there is a broken wire. Because the gun whip takes the most abuse it is most likely that the whip has failed. Disconnect the crossover wires on the machine end of the whip hose and connect the two wires together coming off the 50' section, turn on the hose heat and see if the hose heat circuit is operating, if so replace the whip. To take a continuity reading through the heated hose one of the leads from the transformer to the "A" or "R" heated hose must be disconnected.

If no voltage is coming out of the transformer to the heated hose move on to the next step.

6. Open the console top and locate the solid state relay for the hose circuit, looking over the console top (front of machine) it is the relay to the right. With the hose turned on and there is a LED light lit on the relay take a volt meter that is set on AC volts and measure across position L1 and L2 (heavy wires). With the relay functioning properly you should have a 1 volt reading, if you have a 208-230 volt reading the relay has malfunctioned and needs to be replaced.

If there is no light on the solid state relay move to the next step.



PMCA-20 Manual

7. With a DC volt meter read across position A1 and A2 on the solid state relay (smaller wires) if you have a reading of 4-6 volts DC replace the solid state relay.
If there is no DC voltage to the relay move to the next step.
 8. Using a DC volt meter, measure across positions 9 and 10 on the back of the hose controller. This is the output of the controller and sends power to the solid state relay. Your reading will be **4-6 volts DC**. If there is no reading, check to make sure that the set temperature of the controller is above ambient temperature. Before replacing the controller, measure across position 1 and 2 to make sure that the controller is powered up. Your reading will be 208 to 230 volts AC.
If no voltage is present check for loose wires.
-

PROBLEM

Hose does not heat and the display on the controller shows an error message.

SOLUTIONS

1. Check position 6 and 7 on the heater controller for loose wires.
If the wires are tight move to the next step.
 2. Remove the transformer cover and check that the thermocouple wires are secure to the harness going up to the controller. If there are no loose connections disconnect the wire from the TSU and connect it directly to the thermocouple harness coming out of the hose transformer.
If the controller still shows the error code replace the hose thermocouple.
If the error code goes away and temperature is now shown on the display of the controller then all the TSU harnesses from the TSU to the transformer need to be checked for loose connectors or one or more of the harnesses are defective.
-

PROBLEM

Heated hose controller shows excessive temperature.

SOLUTIONS

1. Set the controller set point at least 20 degrees lower than the temperature shown on the controller. Briefly turn on the hose and look for the LED light on the solid state relay to be on.
If the light is on replace the controller.
If the light is off replace the solid state relay.



PMCA-20 Manual

PROBLEM

Hose will heat but does not come up to set temperature.

SOLUTIONS

1. Check the tap setting on the transformer to ensure that the correct position has been selected for the length of hose being used. Depending on the machines incoming voltage you may have to move the tap setting higher (up one).

CAUTION! Do not exceed the value of the transformer hose breaker.

WARNING! Before correcting any kind of defect, make sure the Main Power Switch is OFF and incoming power is locked OFF. NEVER access the inside of the Control Panel with the Proportioner power supply ON. The Pneumatic Unit is a component that works under pressure. Do not open any connection or carry out maintenance on components subject to pressure until all pressure has been bled to zero.



PMCA-20 Manual

Pneumatic Drive System

NOTE! Follow the recommended procedure in the indicated order to solve the problem and avoid unnecessary repairs. Make sure all Switches are in the correct position and Indicator Lights are ON before determining the existence of a fault.

PROBLEM

Pumps have stalled, the pressure on the chemical gauges is lower than normal and the pump switch light is ON.

SOLUTIONS

1. Check the reversing switches.

CAUTION! BEFORE CONTINUING; DISCONNECT THE MAIN POWER THEN CHECK THAT THE REVERSING SWITCH STRIKER PLATE IS NOT ON ONE OF THE REVERSING SWITCH ROLLERS, IF IT IS PUT THE PUMP SWITCH IN THE OFF POSITION AND PUSH IN ON THE MANUAL OVER RIDE LOCATED ON THE REVERSING VALVE. PUSH IN ON THE GREEN BUTTON IF THE REVERSING SWITCH PLATE IS ON THE LEFT ROLLER OR PUSH IN ON THE ORANGE BUTTON IF THE REVERSING SWITCH IS ON THE RIGHT ROLLER, THIS WILL MOVE THE PLATE OFF THE ROLLER.

2. Remove the reversing switch cover and the clear plastic cover that protects the “R” side pump shaft. With an ohms meter take a continuity reading on the left switch (facing the machine) by touching the two screws that have the wires attached (normally open), there should be no continuity until the roller on the switch is depressed. If this switch is good check the one on the right by touching the two screws that have the wires attached (normally closed, you should have continuity until the roller is depressed.

If both switches are good move to the next step.

3. Check the reversing valve relay located inside the control console, this relay gets its signal from the reversing switches to send power down to the directional valve coils. The relay is a double pole double throw relay and will send 24 volts DC down to one of the two directional valve coils depending on which reversing switch is activated.

If the relay is not defective move on the next step.

2. Check for loose wiring to the directional valve.

If the valve is getting 24 volts DC from the relay replace the directional valve.



PMCA-20 Manual

PROBLEM

Pumps have stalled, pressures on the chemical gauges are lower than normal and the pump switch light is OFF.

SOLUTIONS

1. Remove the two wires located on the “A” and “R” overpressure switches and check for continuity through each switch, the switches should be normally closed.

If there is no continuity replace the switch.

PROBLEM

Pumps have stalled, the pressures on the chemical gauges are higher than normal and the pump switch light is OFF.

SOLUTIONS

1. Check that the pressure on the chemical gauges has not exceeded the factory overpressure setting. If both chemical pressures have exceeded the pressure setting on the high pressure shut off switches check to see if the pneumatic pressure control (air regulator) is not set too high. If one of the chemical gauges reads high and the other low, then you need to balance the pressures. Open the manual valve on the side that has the higher reading. This will drop the pressure on the high side and bring up the pressure on the low side, when the pressures are within 200 psi (13.8 bar) of each other close the manual valve. The pump light will come back on if this was the problem and the pump circuit will be activated. If the problem continues refer to the troubleshooting section of the metering pump line or the spray gun manual.

If the pump light does not come back on go to the next step.

2. Check that the wires attached to each pressure switch are secure. Remove the terminal lugs on the two high pressure shut off switches located on the pre-heater and take a continuity reading across the two terminals on the switch.

If one of the switches is open the switch is defective or out of adjustment.

Replace the switch.

PROBLEM

With the Pump Switch in the normal position, pumps fail to develop pressure due to air loss.

SOLUTIONS

1. Check that the air regulator is not backed all the way out.
2. Check that the compressor is operating properly and that all valves are open.
3. Check that the pneumatic air motor is not leaking.



PMCA-20 Manual

Metering Pump Line

NOTE! Follow the recommended procedure in the indicated order to solve the problem and avoid unnecessary repairs. Make sure all Switches are in the correct position and Indicator Lights ON before determining the existence of a fault.

1. Safety Pressure Switch

Each Metering Pump has a Safety Pressure Switch (H, I, page 11) set to 2,000 psi (137.9 Bar) for size 60 pumps, 2600 psi (179.3 Bar) for size 40 pumps. When the material system reaches this pressure, the Safety Pressure Switch will remove power from the Directional Valve and Direction Indicator Lights. Lack of Direction Indicator Lights along with high pressure indicated on one or both of the material Pressure Gauges is an indication of an over-pressure condition. The Safety Pressure Switches are a momentary design; when the pressure bleeds off, the Metering Pump Line will resume normal operation. However, the cause of the over-pressure should be determined and corrected. The three most common causes are:

- a. Cavitation of the Metering Pump on the low pressure side causing high pressure on the opposite side.
- b. A restriction in the Spray Gun on the high pressure side.
- c. Air pressure set too high.











2. Pressure/Material Imbalance

In summary troubleshooting this problem requires the applicator to:

- a. Know what the NORMAL spray pressures are for the application in progress.
- b. Determine what material is NOT exiting the Mixing Chamber.
- c. Read the Pressure Gauge on the problem side and interpret the reading.



PMCA-20 Manual

MATERIAL CONDITION	"A" GAUGE	"R" GAUGE
NORMAL		
LACK OF ISO (A)		
LACK OF POLY (R)		
RESTRICTION OF ISO (A)		
RESTRICTION OF POLY (R)		



PMCA-20 Manual

3. Cavitation

Cavitation occurs when the Metering Pump requires a larger volume of material than the supply system (Transfer Pump) can furnish. This creates a “void” of material in the Metering Pump. The most common causes of cavitation are:

- a. Material temperature is too low causing increased material viscosity resulting in the inability of the Transfer Pump to maintain sufficient supply to the Metering Pump. This is most common with today’s 245fa blown systems. Ensure the material temperature in the drums is no lower than the material suppliers’ recommendation.
- b. Failure to vent the material drum while drawing material out with the Transfer Pump causes a vacuum and cavitation in the Transfer Pump. Ensure the drum is vented to the atmosphere or a Desiccated Air Dryer Kit is installed as recommended by the material supplier.
- c. Air volume insufficient for Transfer Pump or Transfer Pump Air Valve partially closed will limit the ability of the Transfer Pump to operate at its maximum capability.
- d. Inlet Material Screen obstructed (See MAINTENANCE section).
- e. Metering Pump Inlet Ball does not seat properly allowing material to flow back into the Material Delivery Hose when the Metering Pump is on the “Discharge” stroke. This causes the volume of material on that Metering Pump to be less on the discharge stroke resulting in intermittent off-ratio material and Pressure Gauge fluctuation.

4. Pressure Loss: Discharge/Inlet Ball

Simultaneous observation of the material Pressure Gauge and Direction Indicator Light is necessary to determine which direction the Metering Pump fails to maintain pressure. Refer to the chart to determine problem:

	Left Directional Indicator Light ON	Right Directional Indicator Light ON
Iso Pressure Gauge FALLS	Iso Inlet Ball does not seat properly	Iso Discharge Ball does not seat properly
Poly Pressure Gauge FALLS	Poly Discharge Ball does not seat properly	Poly Inlet Ball does not seat properly

In most cases the cause of a leaking Inlet/Discharge Ball is foreign material preventing the Ball from seating properly. If the above steps do not resolve the problem, replace the appropriate Ball, Ball Seat and Ball Seat Gasket.

For service see MAINTENANCE/Metering Pump Line.



PMCA-20 Manual

MAINTENANCE

NOTE! To achieve maximum output from the PMCA Proportioner, a daily or regular maintenance schedule is required.

Inlet Material Screens

Inspection of the Inlet Material Screens on a daily basis is no longer necessary as long as the following conditions are met.

1. Material drums are stored within the recommended material storage temperature range and drums are not opened prior to installing the Proportioner Material Transfer Drum Pumps.
2. Desiccated air dryers are used to dry replacement air as material is removed from the drums to the Proportioner.
3. Consolidation of old material into a common drum for use is minimized especially the Iso "A".

If the above conditions are met, inspection of the Inlet Material Screens may be done on a **bi-weekly** basis.

NOTE! Inspect and clean Inlet Material Screens before Proportioner start-up. They should not be cleaned after the day's operation as the Proportioner should be purged immediately after inspection and cleaning. This is to reduce the risk of moisture contamination, contamination through the reaction with the solvent used in the cleaning operation and cross-over at the Spray Gun due to air entrapment.

To check the Inlet Material Screens, proceed as follows:

CAUTION! Make sure the Main Power Switch is OFF and incoming power is locked OFF.

1. CLOSE the Poly "R" Proportioner Inlet Valve.
2. Place a suitable container under the Material Inlet Strainer to collect the residual material. Carefully loosen the Strainer Plug allowing the material to drain into the container.
3. Completely unscrew the Strainer Screw.
4. Remove the Seal, Spring and Screen and clean them with a suitable solvent. Dry the parts and ensure the Screen is not obstructed. Replace the Screen if

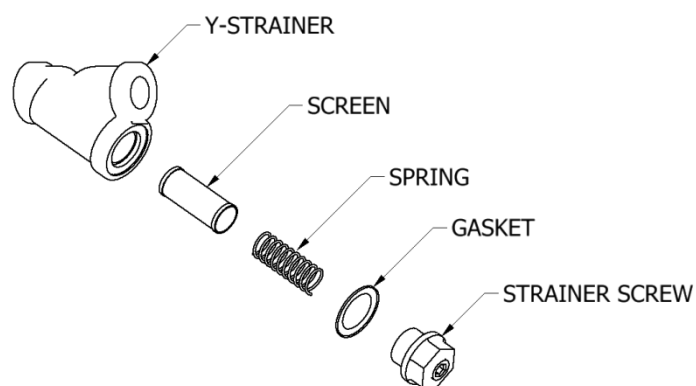



PMCA-20 Manual

- more than 20% of the Screen surface is obstructed by residue.
5. Reinstall the Screen, Spring and Seal. Screw on the Strainer Screw and screw in Plug.
 6. OPEN the Poly "R" Proportioner Inlet Valve, pressurize the Material Transfer Pump, check for leaks.
 7. Repeat above for the Iso "A" side.
 8. Proceed with Proportioner Purging operation (page 18).

Iso Pump Lube System

Daily: Check the condition of the PMC Lube Oil in the Iso Lube Reservoir. Replace the PMC Lube Oil if you see significant changes in the color or signs of solidification. Ensure inside of Reservoir is wiped clean.

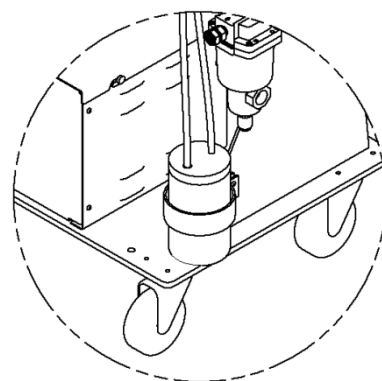

To replace the Lube Oil, proceed as follows:

1. Remove the Lube Reservoir from its support, unscrew the Lid and remove the Check Valve from the Suction Hose.
2. Empty the contaminated Lube Oil in a waste container and refit the Check Valve in the Suction Hose.
3. Clean the Reservoir, refill with Lube Oil, and screw on the Lid and place the Reservoir in its support.

The system is auto-suction and does not need priming when using size 60 pumps. When using size 40 pumps priming may be necessary.

Metering Pump Line

WARNING! Before performing any maintenance, make sure the Main Power Switch is OFF and incoming power is locked OFF. Allow material temperature to cool below 80°F and bleed all material pressure to zero.

Weekly: When the Proportioning Pumps are functioning properly it is not unusual to a small amount of Poly "R" material to appear on the Pump Shaft. This material should be wiped away so dirt does not accumulate on the Pump Shaft and the Pump Shaft Packings are not damaged.

Yearly or as required: Assuming the Iso "A" and Poly "R" is free from contaminants, the maintenance of the Iso Lube Reservoir is performed, and the maintenance of the Poly "R" Pump Shaft (above) is followed, the Proportioning Pumps will perform for many maintenance free cycles. However, it is not unusually for those who use the PMCA Series Proportioner on a regular basis to rebuild the Proportioning Pumps on a yearly basis when the Proportioner is out of service.





PMCA-20 Manual

Pump Base Service

To service Discharge/Inlet Ball

1. CLOSE appropriate Proportioner Inlet Material Supply Valve and remove the Air Line from the Transfer Pump.
2. Ensure all material pressure in the Proportioner system is zero and remove top screw plug from the top of the pump base.
3. Discharge Ball:
 - a. Remove Discharge Ball with a Magnet, clean Ball and Ball Seat, and inspect for foreign material and flat spot(s) on Ball.
 - b. Using supplied Ball Seat Tool (TL-02), to check for proper Ball Seat/Ball Seat Gasket compression, remove the cage. Snug Seat up to ¼ turn **maximum**.

NOTE! It is recommended to replace the O-Ring anytime the cage is removed.

4. Inlet Ball:
 - a. Perform step 1 & 2 from above.
 - b. Remove Cage and Spring.
 - c. Remove Inlet Ball with a Magnet, clean Ball and Ball Seat, and inspect for foreign material and flat spot(s) on Ball.
 - d. Using supplied Ball Seat Tool (TL-02), check for proper Ball Seat/Ball Seat Gasket compression. Snug Seat up to ¼ turn **maximum**.

Pump Seal Replacement

Refer to Parts Identification Drawings for reference.

NOTE!

- When Iso “A” Proportioning Pump Cylinder is disassembled for service, all parts included in the Seal Kit (KT-05001-60 or KT-05001-40) should be replaced.
- When the Poly “R” Proportioning Pump Cylinder is disassembled for service, all parts included in the Seal Kit (KT-05002-60 or KT-05002-40) should be replaced.
- When assembling Proportioning Pump lubricate all Seals, Piston Rod and Pump Cylinder with #1 Lithium Grease to assist in assembly and minimize Seal damage during re-assembly.
- When the Pump Line End Block is disassembled for service, all O-rings included in the O-ring Kit (KT-05009) should be replaced.
- After reassembly of the Proportioning Pumps torque the Assembly Bolts to 30 ft-lbs (40 N-m).

CAUTION! Use wooden or plastic tools or a brass brush for cleaning. Do not use metal or abrasive tools that can scratch the contact surfaces.



PMCA-20 Manual

Material Heater

WARNING! Before performing any maintenance, make sure the Main Power Switch is OFF and incoming power is locked OFF. NEVER access the inside of the Control Panel with the Proportioner power supply ON. The Heaters are components that reach high temperatures; you must wait until they have cooled before handling and bleed all material pressure to zero.

Thermocouple Replacement

Note! The Thermocouple is assembled into the Connector Body with a Ferrule and Nut. Once inserted into the Body and the Nut is tightened, the Ferrule locks to the Thermocouple and does not allow it to be relocated or moved. The location of the Thermocouple is very important and must be done correctly before tightening the Nut.

1. Unscrew the Nut that holds the defective Thermocouple and remove from the Body. Disconnect Thermocouple wiring located under the Top Cover of the Heater. Remove Body and discard.
2. Install Connector Body into Heater using an open-end wrench and tighten to prevent leakage. Teflon Tape or appropriate Thread Sealant should be used.
3. Slide the Nut and the Ferrule over the Thermocouple and insert this assembly into the Connector Body until it comes into **positive physical contact** with the Heating Rod. Make sure the Spring does not prevent the Thermocouple from making contact with the Heating Rod.
4. Slowly tighten the Nut using an open-end wrench, ensuring the Thermocouple maintains positive physical contact with the Heating Rod.
5. Reinstall the Thermocouple wires.

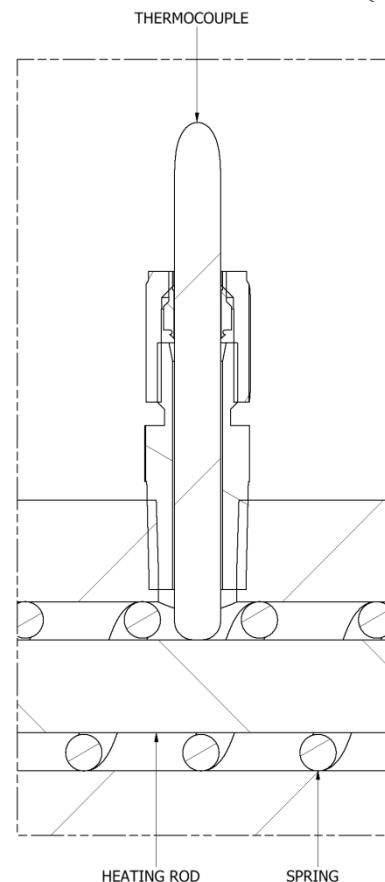
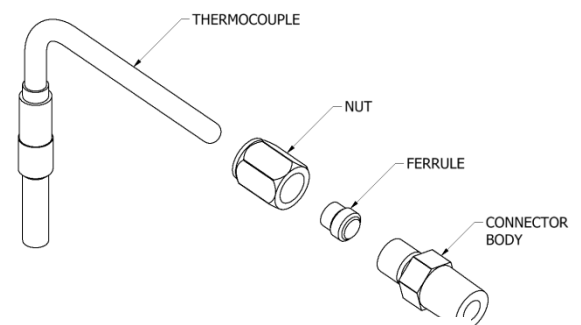



PMCA-20 Manual

WARNING! Before performing any maintenance, make sure the Main Power Switch is OFF and incoming power is locked OFF. NEVER access the inside of the Control Panel with the Proportioner power supply ON. The Heaters are components that reach high temperatures; you must wait until they have cooled before handling and bleed all material pressure to zero.



Heating Rod

To replace a defective Heating Rod proceed as follows:

1. Ensure Main Power Switch is OFF and incoming power is locked OFF. Depressurize proportioner and, remove the top and side Cover on Heater.

Warning! If the Heating Rod to be replaced is the one in contact with the Thermocouple, it is necessary to remove the Thermocouple first. Do not loosen or tighten Thermocouple Body.

2. Disconnect the suspect Heating Rod from the wire connections and test Heating Rod again for proper electrical resistance. 1250 W Heating Rod is 39.0 ohms.
3. Unscrew the Heating Rod and remove from the Heater Block along with its Spring and inspect; it must be smooth and shiny in appearance. If it is blackened or has material adhered to it replace the Heating Rod even if ohm reading is acceptable.
4. Apply Teflon Tape or appropriate Thread Sealant to the Heating Rod thread and assemble Heating Rod and Spring into the Heater Block.

Tighten securely to 110 ft-lbs (149 N-m).

5. If necessary carefully re-install Thermocouple ensuring positive physical contact with the Heating Rod. Make sure the Spring does not prevent the Thermocouple from making contact with the Heating Rod. Tighten Nut with open-end wrench.
6. Reconnect wire connections and replace the side and top Cover.
7. Ensure Heater is full of material prior to electrical testing.



PMCA-20 Manual

REPLACEMENT KITS

60 A PUMP REBUILD KIT* (KT-07004)		
PART NUMBER	QTY	DESCRIPTION
OR-00011A	2	O-Ring; 12x2mm ID
OR-00020A	2	#136 Viton Lube Cylinder O-Rin
OR-00044A	1	O-Ring #024; Lube Cylinder
OR-00046A	2	O-Ring #133; Viton 90D Pump Cy
PU-01013A	1	Cylinder Flange Gasket
OR-00051B	1	O-Ring; #218 Aflas 80D
PU-05029-60	1	Pin
PU-03002	1	Triple Lip Seal, 60 Pump
PU-03007	1	Shaft Bearing, 60, "A" Side
PU-03016	1	Retaining Ring, 80, ""A"" Side
PU-05043	1	Piston Bearing, 60
PU-03021	1	A Side Seal Tool
PU-03022	1	Bullet, 60
PU-01017A-006	1	Cylinder Seal; 60 Pump
TN-04199	2	SHCS, Bolt, 3/8-24 x 2.5
OR-00045A	2	O-Ring #028 Viton 90D
OR-00051B	1	O-Ring #218 Alfas 80D
PU-01003-IG	1	Discharge Ball Seat Gasket
PU-01003-DG	1	Inlet Ball Seat Gasket
PU-05023-1	1	Gasket; Pump Retainer Nut

*Assembly instructions included in kit.



PMCA-20 Manual

60 R PUMP REBUILD KIT* (KT-07005)		
PART NUMBER	QTY	DESCRIPTION
OR-00011A	2	O-Ring; 12x2mm ID
OR-00046A	2	O-Ring #133; Viton 90D Pump Cy
OR-00051B	1	O-Ring; #218 Aflas 80D
PU-01013A	1	Cylinder Flange Gasket
PU-05029-60	1	Pin
PU-03002	1	Triple Lip Seal, 60 Pump
PU-03012	1	Shaft Bearing, 60, "R" Side
PU-05043	1	Piston Bearing, 60
PU-01016A-006	1	Piston Seal; 60 Pump
TN-04199	2	SHCS, Bolt, 3/8-24 x 2.5
PU-03022	1	Bullet, 60
OR-00045A	2	O-Ring #028 Viton 90D
OR-00051B	1	O-Ring #218 Alfas 80D
PU-01003-IG	1	Discharge Ball Seat Gasket
PU-01003-DG	1	Inlet Ball Seat Gasket
PU-05023-1	1	Gasket; Pump Retainer Nut

*Assembly instructions included in kit.



PMCA-20 Manual

40 A PUMP REBUILD KIT* (KT-07006)		
PART NUMBER	QTY	DESCRIPTION
KT-01016A-004	1	Piston Seal; 40 Pump Kit
OR-00011A	2	O-Ring; 12x2mm ID
OR-00020A	2	#136 Viton Lube Cylinder O-Rin
OR-00046A	2	O-Ring #133; Viton 90D Pump Cy
OR-00051B	1	O-Ring; #218 Aflas 80D
PU-01013A	1	Cylinder Flange Gasket
PU-05029-40	1	Pin
PU-03003	1	Triple Lip Seal, 40 Pump
PU-03017	1	Retaing Ring, 40, 28, A Side
PU-03008	1	Shaft Bearing 40, "A" Side
PU-05044	1	Piston Bearing, 40
PU-03021	1	A Side Seal Tool
TN-04199	2	SHCS, Bolt, 3/8-24 x 2.5
PU-03023	1	Bullet, 40
OR-00045A	2	O-Ring #028 Viton 90D
OR-00051B	1	O-Ring #218 Alfes 80D
PU-01003-IG	1	Discharge Ball Seat Gasket
PU-01003-DG	1	Inlet Ball Seat Gasket
PU-05023-1	1	Gasket; Pump Retainer Nut
OR-00044A	1	O-Ring #024; Lube Cylinder

*Assembly instructions included in kit.



PMCA-20 Manual

40 R PUMP REBUILD KIT* (KT-07007)		
PART NUMBER	QTY	DESCRIPTION
KT-01016A-004	1	Piston Seal; 40 Pump Kit
OR-00011A	2	O-Ring; 12x2mm ID
OR-00046A	2	O-Ring #133; Viton 90D Pump Cy
OR-00051B	1	O-Ring; #218 Aflas 80D
PU-01013A	1	Cylinder Flange Gasket
PU-05029-40	1	Pin
PU-03013	1	Shaft Bearing, 40 " R" Side
PU-05044	1	Piston Bearing, 40
PU-03003	1	Triple Lip Seal, 40 Pump
PU-03023	1	Bullet, 40
TN-04199	2	SHCS, Bolt, 3/8-24 x 2.5
OR-00045A	2	O-Ring #028 Viton 90D
OR-00051B	1	O-Ring #218 Alfas 80D
PU-01003-IG	1	Discharge Ball Seat Gasket
PU-01003-DG	1	Inlet Ball Seat Gasket
PU-05023-1	1	Gasket; Pump Retainer Nut

*Assembly instructions included in kit.



PMCA-20 Manual

Proportioning Pump Line O-ring Kit (KT-05009)

PART NUMBER	DESCRIPTION	QTY
OR-00011A	O-ring	4
OR-00046A	O-ring	4
OR-00045A	O-ring	4
PU-01013A	Gasket	2
OR-00044A	O-ring	1
OR-00020A	O-ring	2

PMC Recommended O-ring Grease

PART NUMBER	DESCRIPTION	QTY
GP-Lube Grease	Lubriplate Grease	1
TL-04003	Grease Tube for use w/ Grease Gun	1

Heater Thermocouple Kit (KT-05021)

PART NUMBER	DESCRIPTION	QTY
HI-05020	Body, Nut, Ferrule	1
HI-05021	Thermocouple	1

Hose Heat Connector Kit (KT-00029A)

PART NUMBER	DESCRIPTION	QTY
KT-00029A-1	Hose Heat; Connector Body	1
KT-00029-4	Wire Terminal	3



PMCA-20 Manual

DOUBLE ACTING PROPORTIONING PUMP DIAGRAM

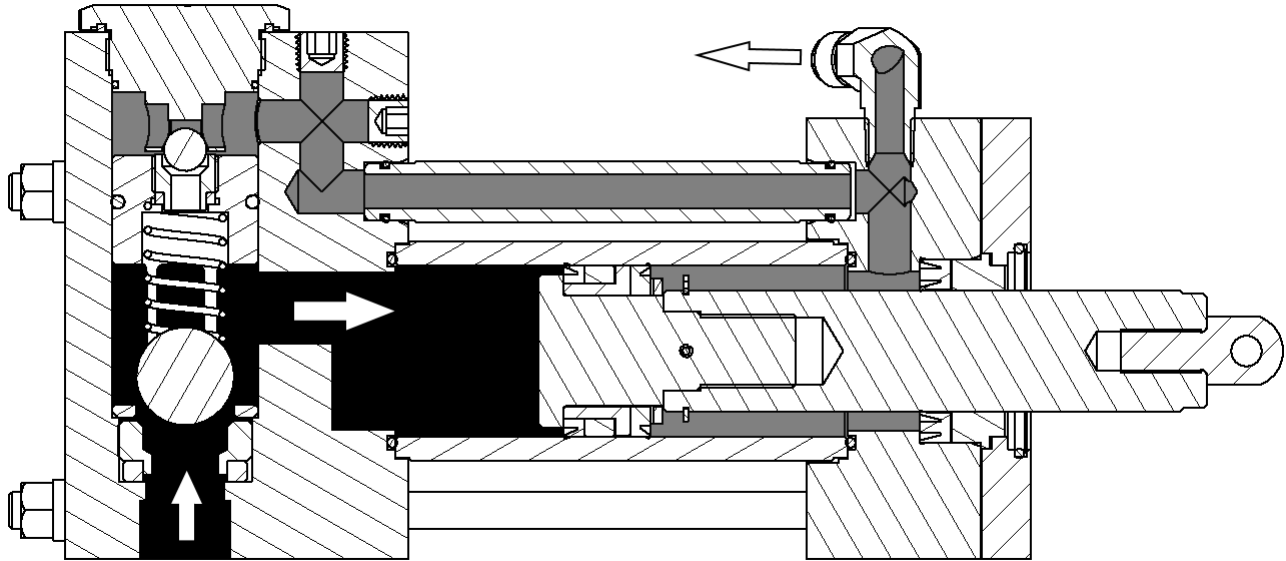

FILL STROKE

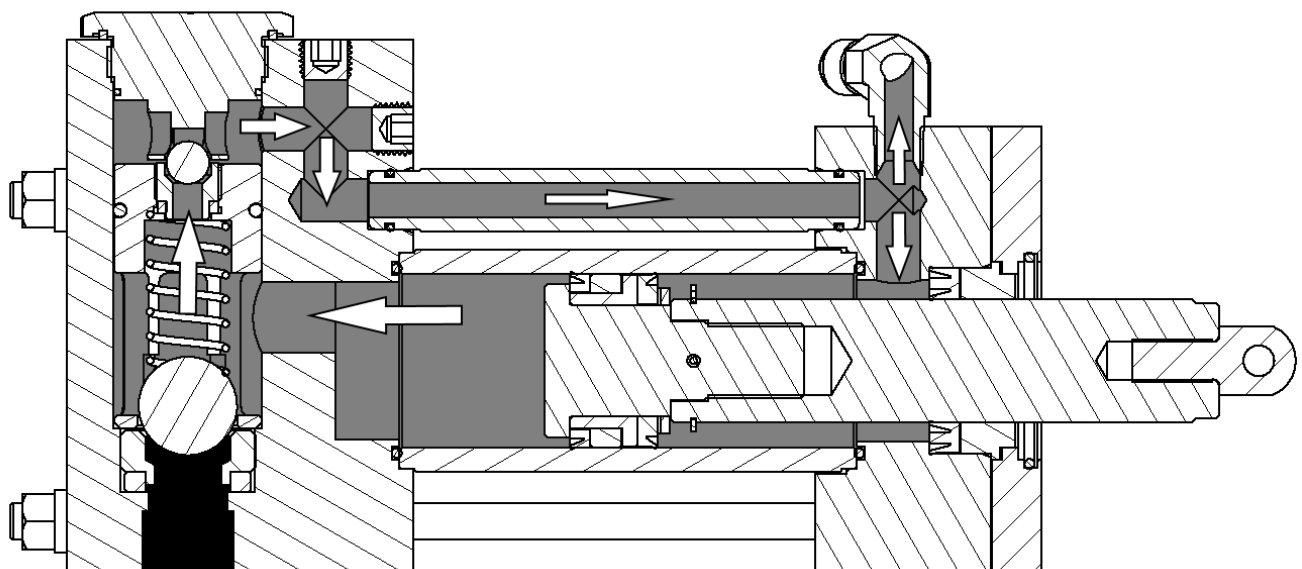

DISCHARGE STROKE



PMCA-20 Manual

PART IDENTIFICATION

Pump Line Assembly (PL-4 & PL-5)

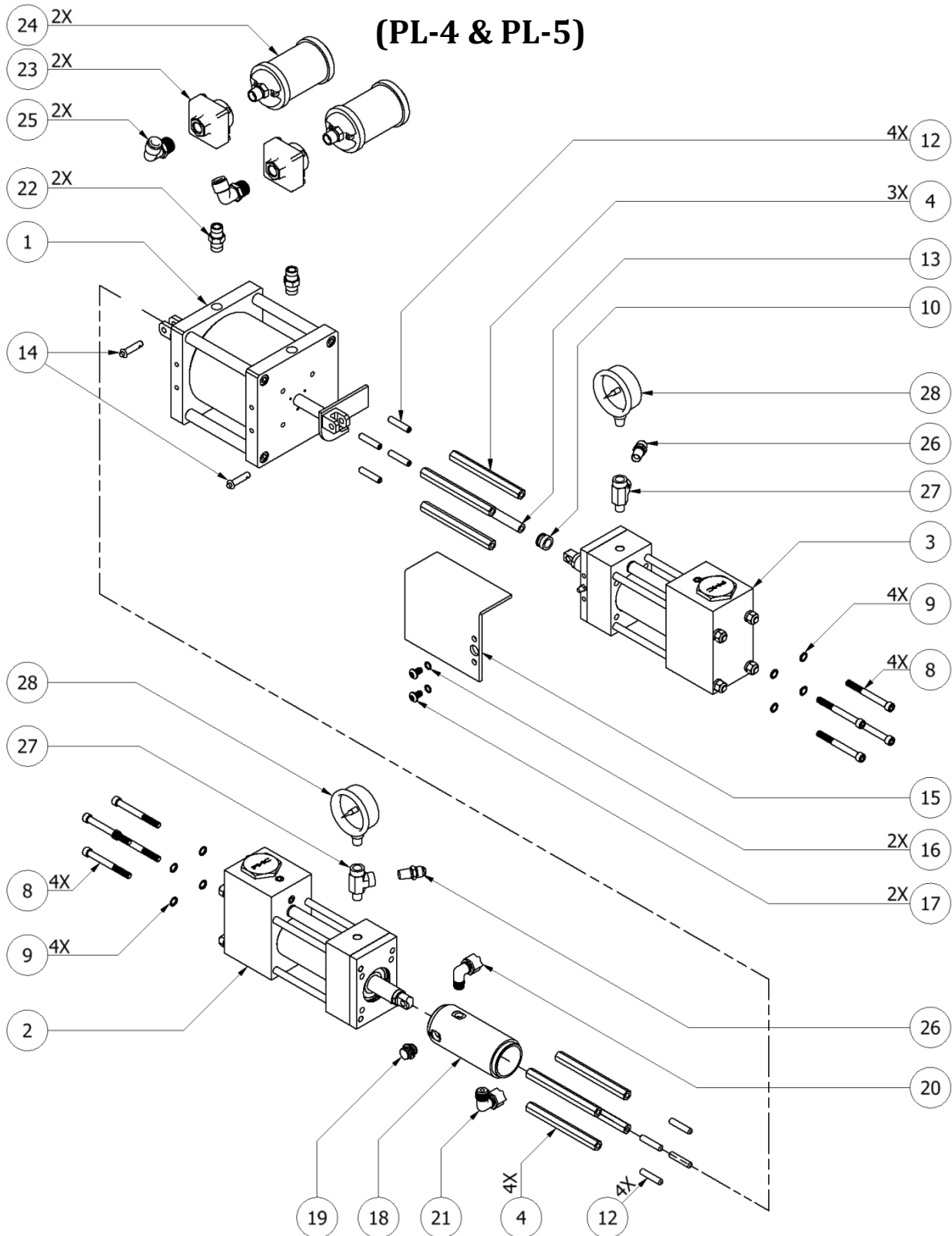



PMCA-20 Manual

PUMP LINE ASSEMBLY (PL-4 & PL-5)			
ITEM	QTY	PART NUMBER	DESCRIPTION
1	1	NE-06009A	AIR MOTOR ASSEMBLY (PAGE 49)
2	1	PU-05001-60	"A" PUMP ASSEMBLY; SIZE 60 (PL-4) (PAGE 51)
	1	PU-05001-40	"A" PUMP ASSEMBLY; SIZE 40 (PL-5) (PAGE 51)
3	1	PU-05002-60	"R" PUMP ASSEMBLY; SIZE 60 (PL-4) (PAGE 53)
	1	PU-05002-40	"R" PUMP ASSEMBLY; SIZE 40 (PL-5) (PAGE 53)
4	7	HI-05025-11	HYDRAULIC STANDOFF
8	8	PU-05008	MOUNTING BOLT
9	8	PU-05008-1	SERRATED WASHER 5/16
10	1	PU-05010	BUSHING
12	8	HI-05065	5/16-24 X 1.5 STUD
13	1	HI-05025-12	REVERSING SWITCH STANDOFF
14	2	PU-05007	CLEVIS PIN
15	1	PU-01027	ACTIVATOR PLATE COVER
16	2	FLOOR STOCK	#011 O-RING
17	2	FLOOR STOCK	5/16-18 X 0.5 HEX SOCKET BHCS
18	1	PU-05003	LUBE CYLINDER
19	1	RA-00065A	PUMP CYLINDER PLUG
20	1	RA-06006	1/4 NPT X 3/8 90 DEG
21	1	RA-06007	3/8 NPT X 3/8 90 DEG
22	2	RA-06004	3/8 X 3/8 NPT NIPPLE
23	2	NE-06002	AIR EXHAUST VALVES
24	2	NE-06005	MUFFLER 011100
25	2	NE-06011	QUICK LOCK TUBE FITTING; 90 DEG
26	2	HI-05031	1/4 NPT X 9/16-18 JIC
27	2	GP-00100-3	MALE RUN TEE X FEMALE PIPE 1/4
28	2	HI-05028	PRESSURE GUAGE 0-3000 (PL-4)
	2	HI-05035	PRESSURE GUAGE 0-5000 (PL-5)



PMCA-20 Manual

Air Motor Assembly (NE-06009)

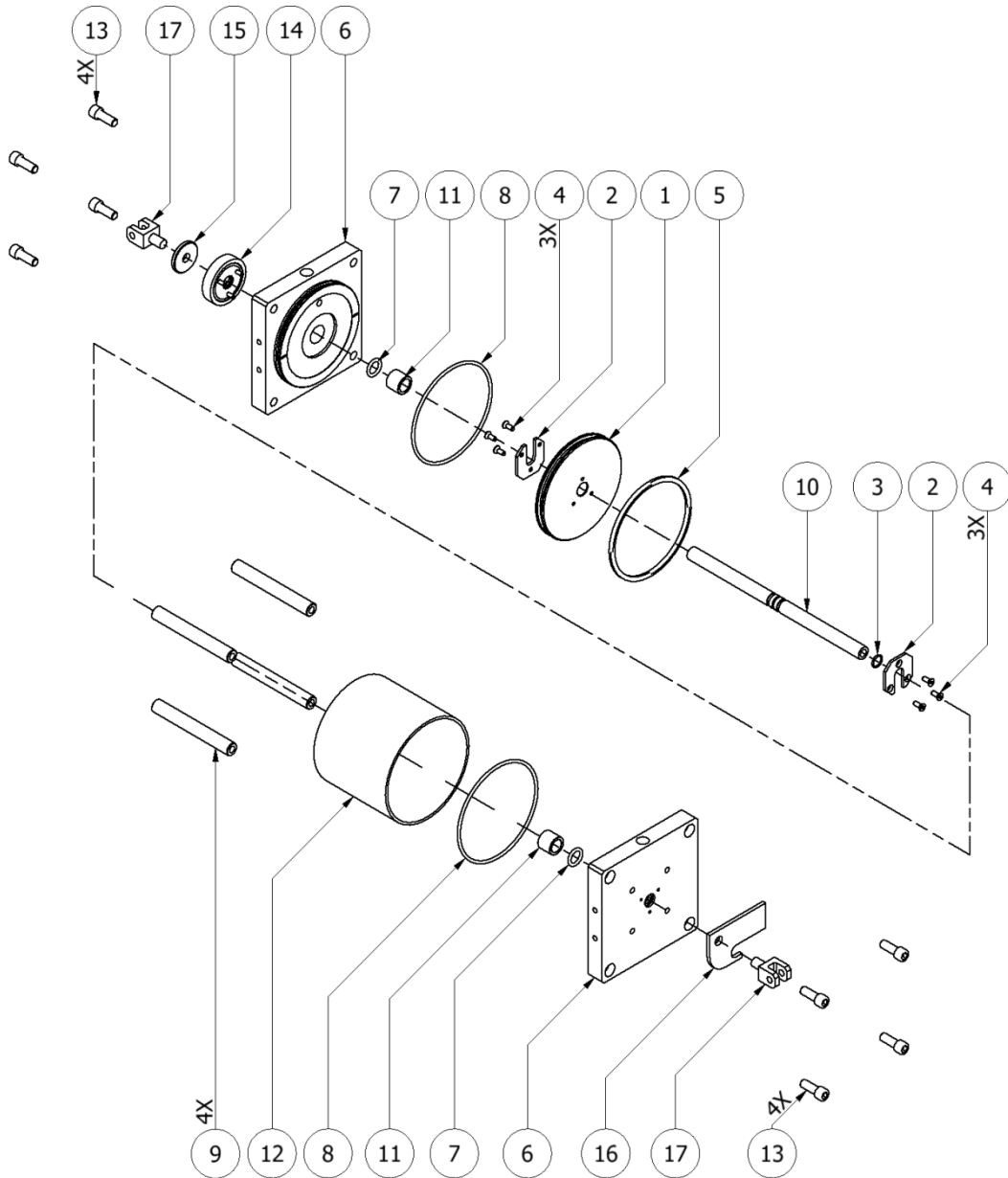



PMCA-20 Manual

AIR MOTOR ASSEMBLY			
ITEM	QTY	PART NUMBER	DESCRIPTION
1	1	NE-0602	PISTON
2	2	NE-604-1	PISTON CLAMP
3	1	OR-00011A	O-RING; CROSSOVER TUBE #014
4	6	NE-06009-9	#10-32 X 0.5 HEX SOCKET FLAT COUNTERSUNK
5	1	OR-00050	O-RING; PISTON
6	2	NE-0606	AIR MOTOR END PLATE
7	2	OR-00048	O-RING; SHAFT
8	2	OR-00049	O-RING; PORT BLOCK
9	4	NE-0607	STAND OFF; AIR MOTOR
10	1	NE-0601	PISTON SHAFT
11	2	NE-0605	PISTON BUSHING
12	1	NE-0603	PISTON CYLINDER
13	8	FLOOR STOCK	3/8-24 X 1 HEX SHCS
14	1	HI-06004	PUMP LUBE END CAP
15	1	PU-05005	BAFFLE
16	1	PU-06009	REVERSING ACTUATOR PLATE
17	2	PU-05006	HYDRAULIC CLEVIS



PMCA-20 Manual

"A" Pump Assembly; Size 60 & 40

(PU-05001-60)

(PU-05001-40)

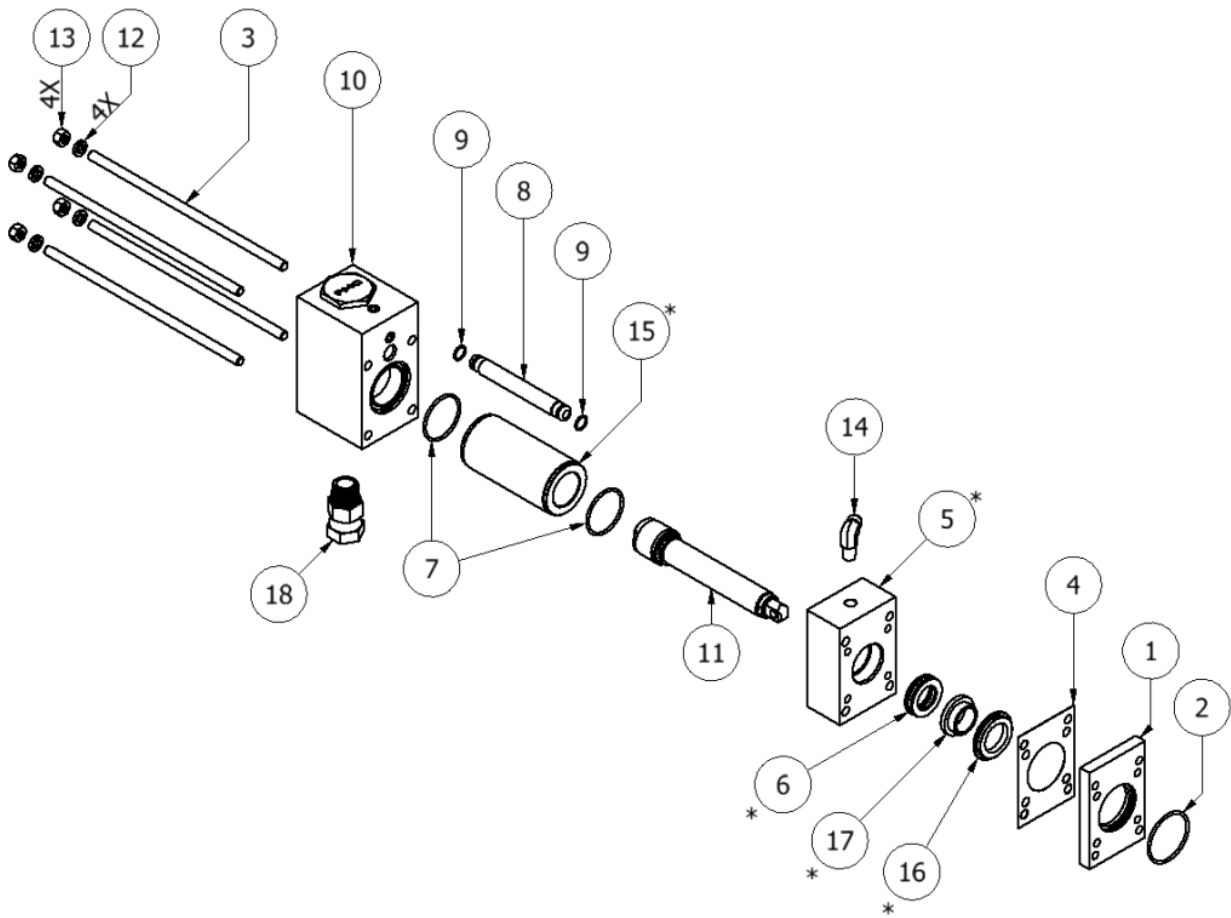



PMCA-20 Manual

"A" PUMP ASSEMBLY				
PU-05001-60				
PU-05001-40				
ITEM	QTY	PART NUMBER	DESCRIPTION	FOR PUMP
1	1	PU-05013	"A" PACKING RETAINER FLANGE	ALL
2	1	OR-00020A	#136 VITON LUBE CYLINDER O-RING	ALL
3	4	PU-05026	TIE ROD; 3/8-24	ALL
4	1	PU-01013A	CYLINDER FLANGE GASKET	ALL
5*	1	PU-05014-60	PUMP FLANGE, 60	PU-05001-60
	1	PU-05014-40	PUMP FLANGE, 40	PU-05001-40
6*	1	PU-03002	TRIPLE LIP SEAL, 60	PU-05001-60
	1	PU-03003	TRIPLE LIP SEAL, 40	PU-05001-40
7	2	OR-00046A	O-RING #133; VITON 90D PUMP CYL	ALL
8	1	PU-05017	CROSSOVER TUBE	ALL
9	2	OR-00011A	O-RING; CROSSOVER TUBE #014	ALL
10*	1	SEE PAGE 56	PUMP BASE ASSEMBLY	-
11	1	SEE PAGE 55	PISTON ASSEMBLY	-
12	4	PU-05027	WASHER	ALL
13	4	PU-05028	NUT	ALL
14	1	HI-05038	1/4 NPT X 9/16-18 JIC 90 DEG E	ALL
15*	1	PU-05012-60	CYLINDER, 60	PU-05001-60
	1	PU-05012-40	CYLINDER, 40	PU-05001-40
16*	1	PU-03016	RETAINING RING, 80, 60, A	PU-05001-60
	1	PU-03017	RETAINING RING, 40, 28, A	PU-05001-40
17*	1	PU-03007	SHAFT BEARING, 60, A	PU-05001-60
	1	PU-03008	SHAFT BEARING, 40, A	PU-05001-40
18	1	HI-05016	3/4 MPT X 3/4 FPT SW	ALL



PMCA-20 Manual

"R" Pump Assembly; Size 60 & 40

(PU-05002-60)

(PU-05002-40)

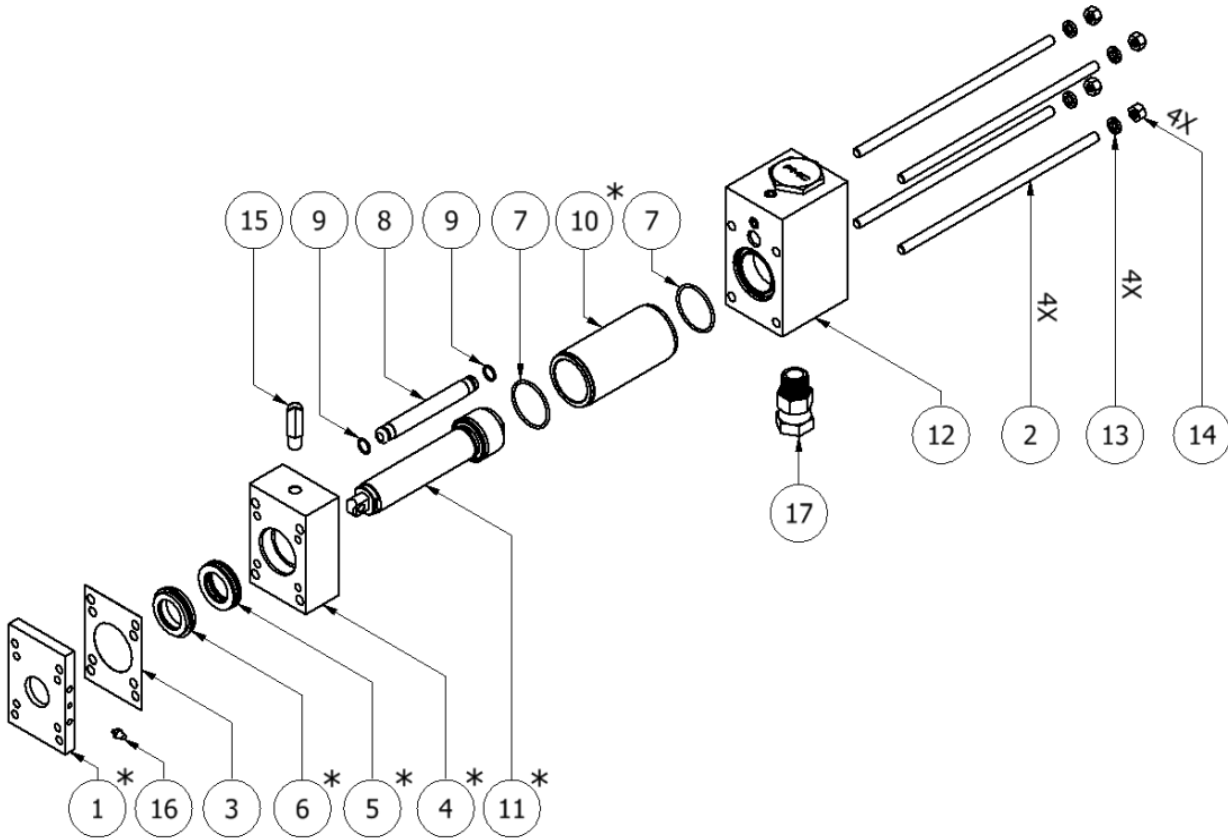



PMCA-20 Manual

"R" PUMP ASSEMBLY PU-05002-60 PU-05002-40				
ITEM	QTY	PART NUMBER	DESCRIPTION	FOR PUMP
1*	1	PU-05032-60	"R" PACKING RETAINER FLANGE; SIZE 60	PU-05002-60
	1	PU-05032-40	"R" PACKING RETAINER FLANGE; SIZE 40	PU-05002-40
2	4	PU-05026	TIE ROD; 3/8-24	ALL
3	1	PU-01013A	CYLINDER FLANGE GASKET	ALL
4*	1	PU-05014-60	PUMP FLANGE; SIZE 60	PU-05002-60
	1	PU-05014-40	PUMP FLANGE; SIZE 40	PU-05002-40
5*	1	PU-03002	TRIPLE LIP SEAL, 60	PU-05002-60
	1	PU-03003	TRIPLE LIP SEAL, 40	PU-05002-40
6*	1	PU-03012	SHAFT BEARING, 60, R	PU-05002-60
	1	PU-03013	SHAFT BEARING, 40, R	PU-05002-40
7	2	OR-00046A	O-RING #133; VITON 90D PUMP CYL	ALL
8	1	PU-05017	CROSSOVER TUBE	ALL
9	2	OR-00011A	O-RING; CROSSOVER TUBE #014	ALL
10*	1	PU-05012-60	CYLINDER; SIZE 60	PU-05002-60
	1	PU-05012-40	CYLINDER; SIZE 40	PU-05002-40
11*	1	SEE PAGE 55	PISTON ASSEMBLY	-
12	1	SEE PAGE 56	PUMP BASE ASSEMBLY	-
13	4	PU-05027	WASHER	ALL
14	4	PU-05028	NUT	ALL
15	1	HI-05038	1/4 NPT X 9/16-18 JIC 90 DEG E	ALL
16	1	TN-04186	GREASE FITTING	ALL
17	1	HI-05016	3/4 MPT x 3/4 FPT SW	ALL

*Indicates different parts for different pump sizes.



PMCA-20 Manual

Piston Assembly; Size 60 & 40

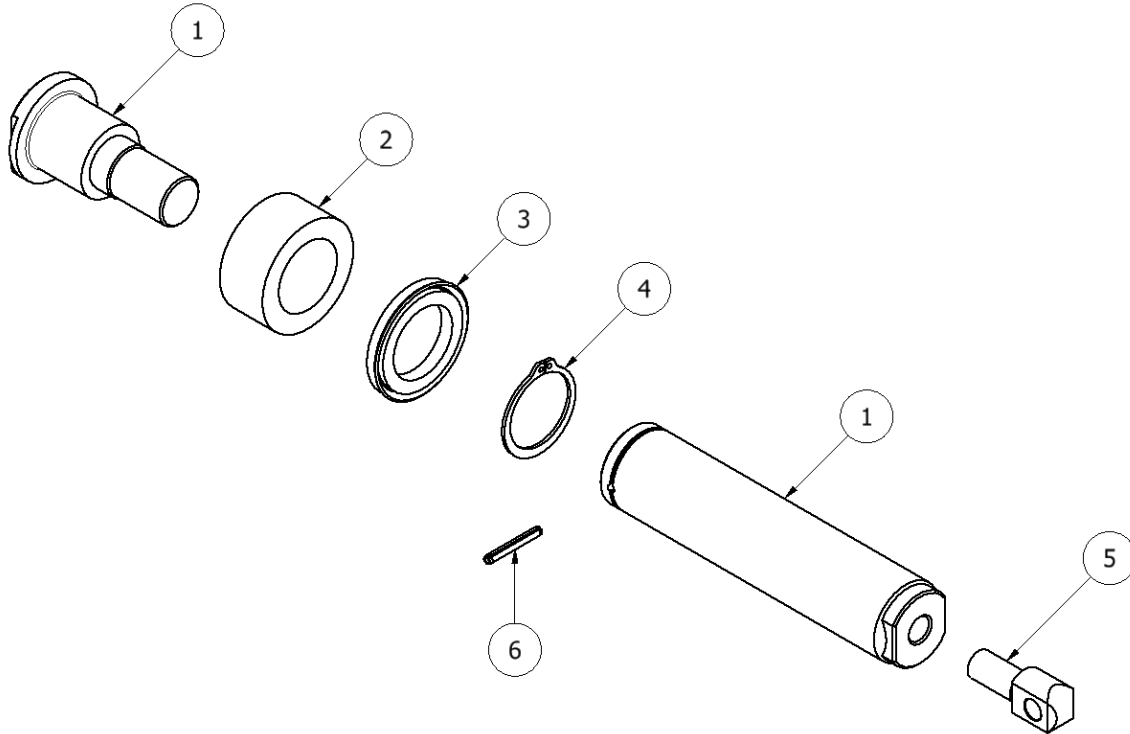

60 PUMP PISTON ASSEMBLY			
ITEM	QTY	PART NUMBER	DESCRIPTION
1	1	PU-05011-60	PISTON SHAFT; SIZE 60
2	1	PU-05043	PISTON BEARING, 60
3	1	PU-01016A-006	PISTON SEAL; SIZE 60
4	1	PU-05030-60	60 SNAP RING
5	1	PU-05031	PISTON CLEVIS
6	1	PU-05029-60	60 SPRING PIN

40 PUMP PISTON ASSEMBLY			
ITEM	QTY	PART NUMBER	DESCRIPTION
1	1	PU-05011-40	PISTON SHAFT; SIZE 40
2	1	PU-05044	PISTON BEARING, 40
3	1	PU-01016A-004	PISTON SEAL; SIZE 40
4	1	PU-05030-40	40 SNAP RING
5	1	PU-05031	PISTON CLEVIS
6	1	PU-05029-40	40 SPRING PIN



PMCA-20 Manual

Pump Base Assembly

PUMPBASE ASSEMBLY			
ITEM	QTY	PART NUMBER	DESCRIPTION
1	1	PU-05018	PUMP BASE
2	1	PU-01003-DG	INLET BALL SEAT GASKET
3	1	PU-05019	INLET SEAT
4	1	PU-05020	INLET BALL
5	1	PU-05021	SPRING
6	1	PU-05022A	SLEEVE
7	1	OR-00051B	#218 AFLAS 80D O-RING
8	1	PU-01003-IG	DISCHARGE BALL SEAT GASKET
9	1	PU-05024	DISCHARGE SEAT
10	1	PU-05025	DISCHARGE BALL
11	1	PU-05023-R	PUMP RETAINER NUT
12	1	PU-05023-1	GASKET
14	2	HI-05067	PIPE PLUG 1/4-18; 7/8 TAPER

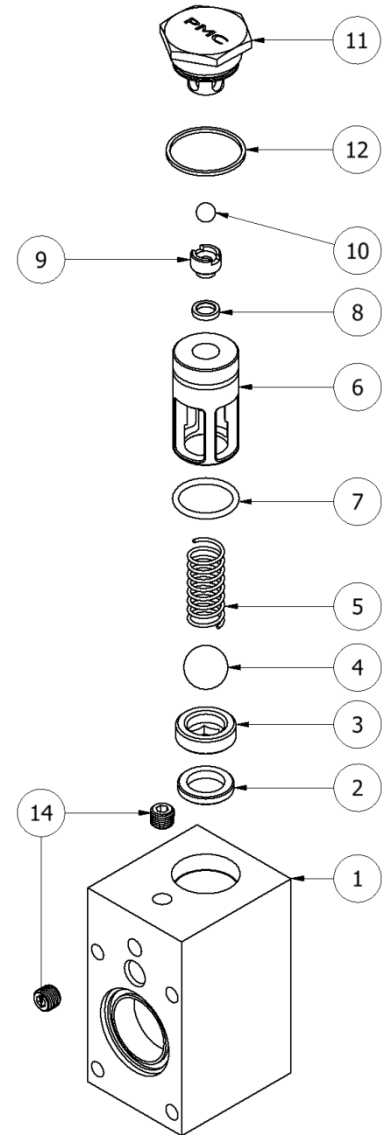



PMCA-20 Manual

Pre Heater Assembly (PH-13)

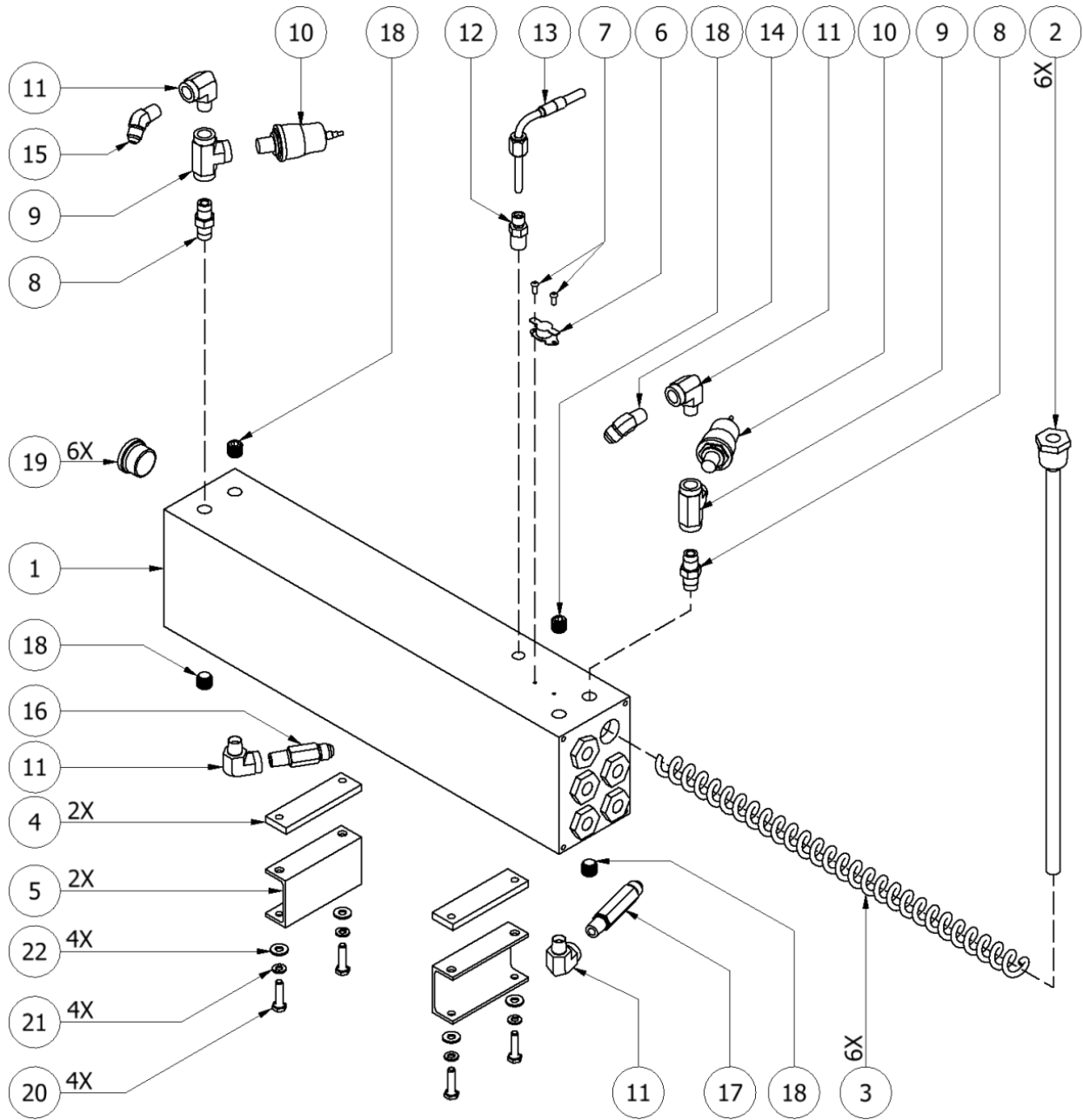



PMCA-20 Manual

PRE HEATER ASSEMBLY (PH-13)			
ITEM	QTY	PART NUMBER	DESCRIPTION
1	1	GM-06423-1	HEATER BLOCK
2	6	GM-05423-1250	FIRE ROD; 1250W, 3/4 NPT, 17.5"
3	6	GM-05423-7	SPRING 18"
4	2	GM-06423-3	PHENOLIC ISOLATOR
5	2	RM-06700-17	HEATER MOUNTING BRACKET
6	1	EL-00006A	OVERTEMP SWITCH
7	2	FLOOR STOCK	#6-32 X 3/8 HEX SOCKET BHCS
8	2	GP-00100-1	1/4 PIPE NIPPLE
9	2	HI-05058	1/4 TEE
10	2	EL-52-2000	PRESSURE SWITCH; 2000 PSI
	2	EL-52-2600	PRESSURE SWITCH; 2600 PSI
11	4	HI-05030	1/4 MNPT X 1/4 FNPT STREET ELBOW
12	1	HI-05020	THERMOCOUPLE NUT
13	1	HI-05021	THERMOCOUPLE; TYPE E
14	1	HI-05026	1/4 NPT X 9/16-18 JIC 45 DEG EL
15	1	HI-05027	1/4 NPT X 1/2-20 JIC 45 DEG EL
16	1	HI-05059	1/4 X #6 JIC ADAPTER
17	1	HI-05060	1/4 X #6 JIC LONG ADAPTER
18	4	HI-05036	1/4 NPT FLUSH SEAL PIPE PLUG
19	6	HI-05034	12 ORB PLUG
20	4	FLOOR STOCK	1/4-20 X 1 HEX CAP SCREW
21	4	FLOOR STOCK	1/4 LOCK WASHER
22	4	FLOOR STOCK	1/4 PLAIN WASHER



PMCA-20 Manual

Y-Strainer Assembly; "A" & "R" Side (YS-1 & YS-2)

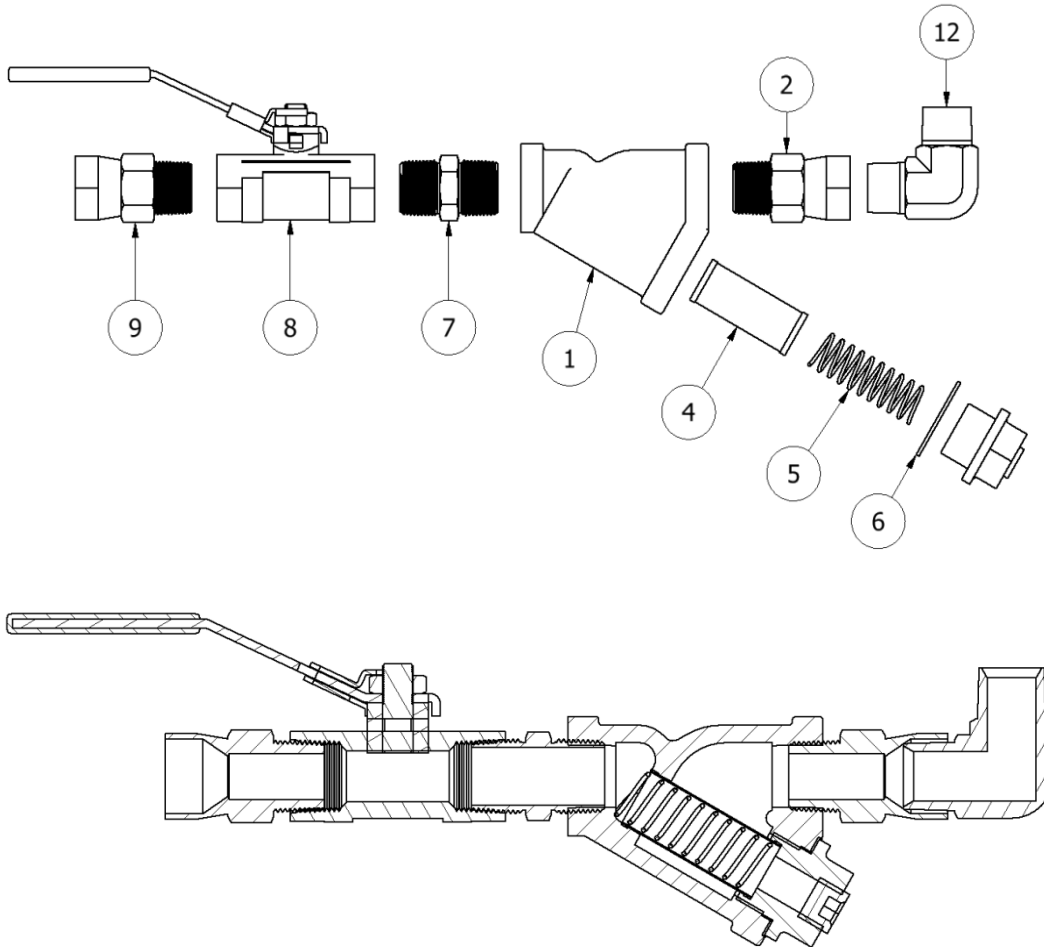

Y STRAINER ASSEMBLY; "A" & "R" SIDE (YS-1 & YS-2)			
ITEM	QTY	PART NUMBER	DESCRIPTION
1	1	RA-00074-00A	Y-STRAINER ASSEMBLY (INCLUDES ITEMS 4, 5, 6)
2	1	HI-05016	3/4" SWIVEL FITTING
4	1	RA-00074-03-30A	REPLACEMENT SCREEN; 30 MESH
	1	RA-0007A-03-60A	REPLACEMENT SCREEN; 60 MESH
	1	RA-0007A-03-80A	REPLACEMENT SCREEN; 80 MESH
5	1	SP-00009A	REPLACEMENT SPRING
6	1	RA-00074-02A	REPLACEMENT GASKET
7	1	HI-05017	3/4" HEX NIPPLE
8	1	RA-00078A	3/4" BALL VALVE
9	1	HI-05016	3/4" X 3/4" SWIVEL FITTING "R" SIDE (YS-2)
	1	HI-05018	3/4" X 1/2" SWIVEL FITTING "A" SIDE (YS-1)
12	1	HI-05015	3/4" NPT ELBOW



PMCA-20 Manual

Air Machine (PMCA-20-1600 & PMCA-20-2400)

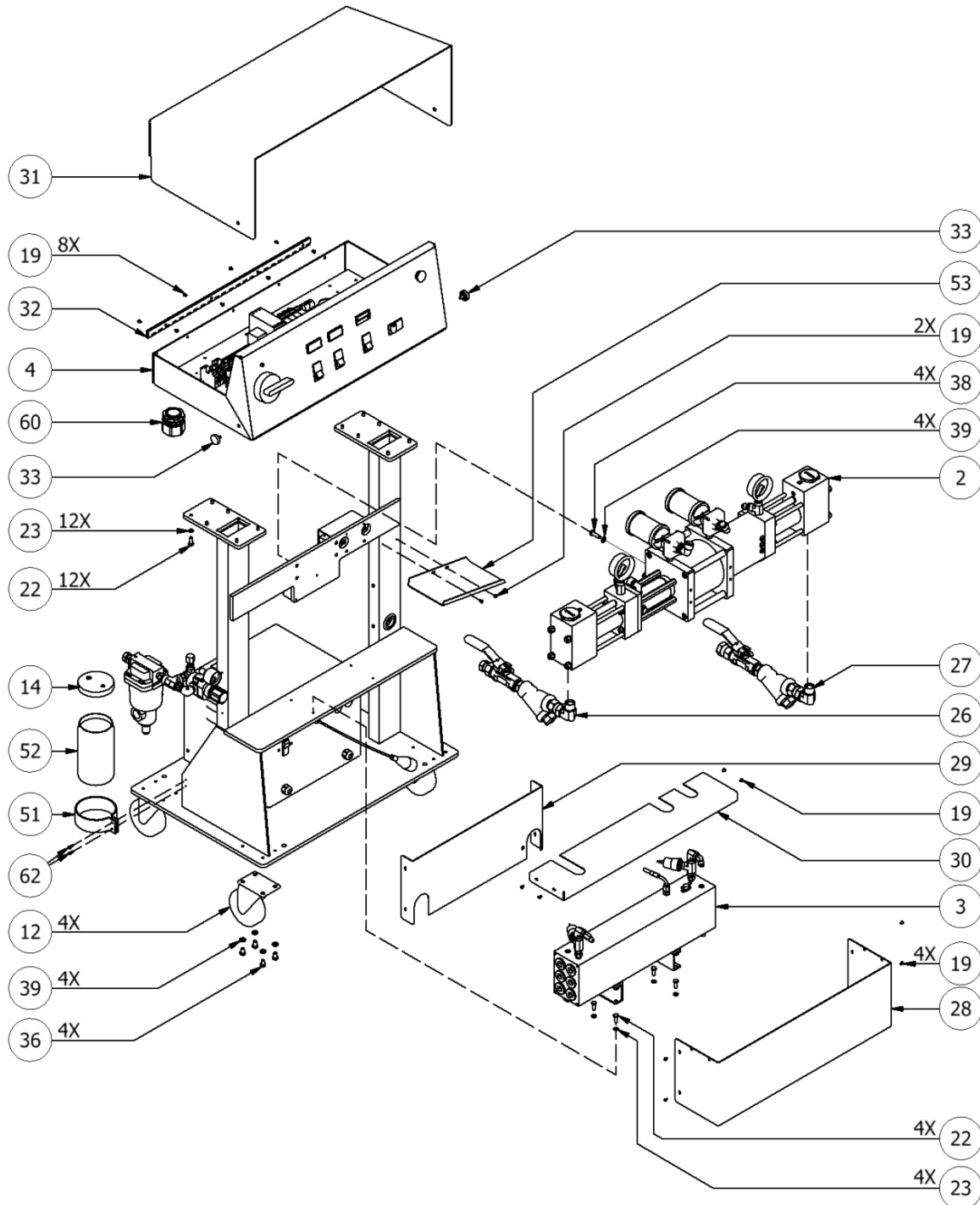



PMCA-20 Manual

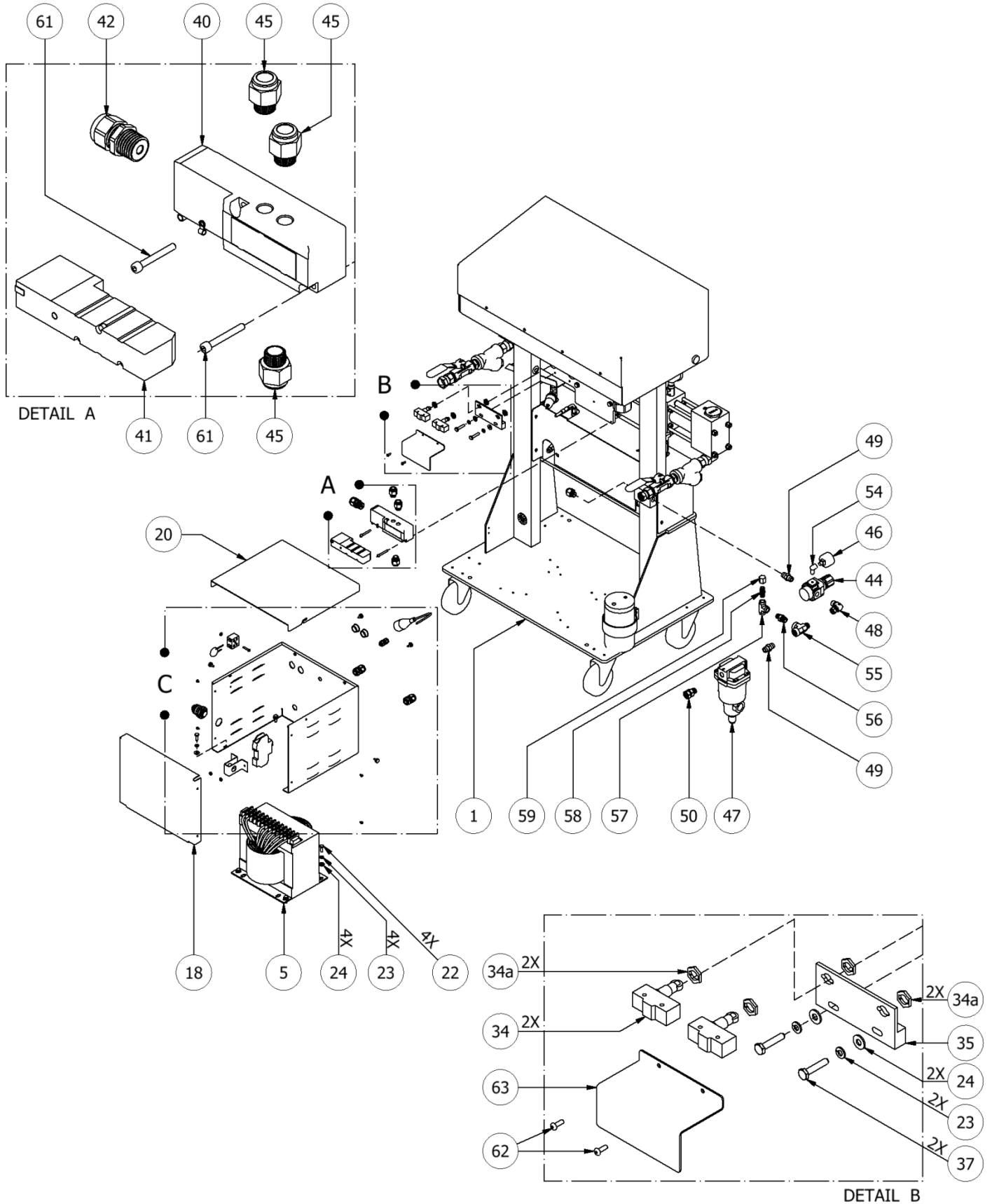



PMCA-20 Manual

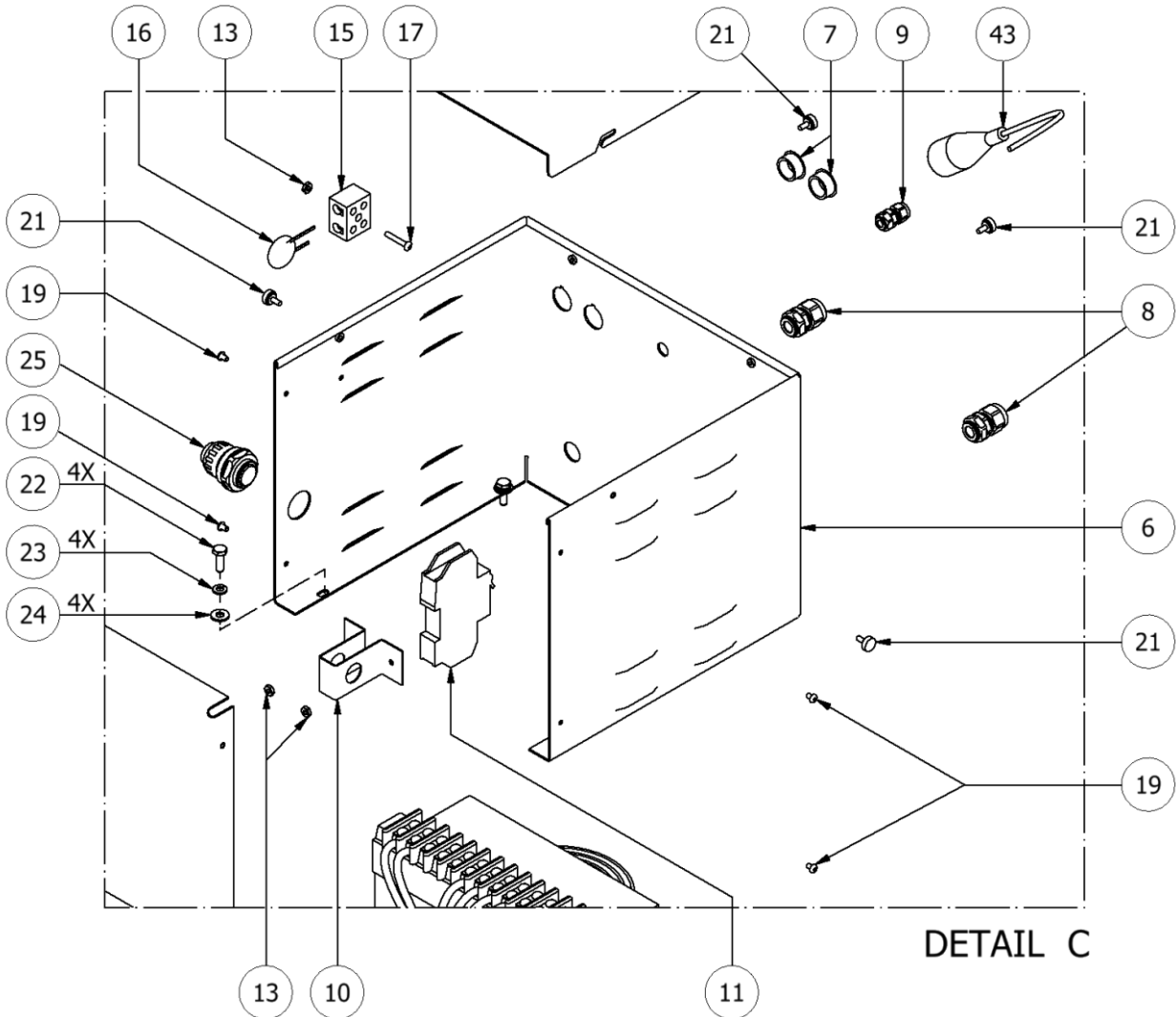

AIR MACHINE (PMCA-20-1600 & PMCA-20-2400)			
ITEM	QTY	PART NUMBER	DESCRIPTION
1	1	FR-3	TANK/BASE ASSEMBLY
2	1	PL-4	PUMPLINE ASSEMBLY; SIZE 60 (PMCA-20-1600) (PAGE 47)
	1	PL-5	PUMPLINE ASSEMBLY; SIZE 40 (PMCA-20-2400) (PAGE 47)
3	1	PH-13	PREHEATER 7500KW (PAGE 57)
4	1	EL-06200	CONSOLE ASSEMBLY
5	1	EL-05225	90V TRANSFORMER
6	1	RM-05700-25	TRANSFORMER COVER; SIDES
7	2	FLOOR STOCK	TRANSFORMER PLUG
8	2	EL-000P12	HEYCO #6
9	1	EL-000P7	HEYCO STRAIN RELIEF



PMCA-20 Manual

10	1	EL-00118A-00-1	HOSE BREAKER MOUNTING PLATE
11	1	EL-39	BREAKER HOSE
12	4	TN-05704	4" SWIVEL CASTER
13	3	FLOOR STOCK	#8-32 NUT
14	1	MQ-01009-02A	LUBE BOTTLE LID
15	1	EL-192	TERMINAL BLOCK
16	1	EL-193	INRUSH CURRENT LIMITER
17	1	FLOOR STOCK	#8-32 CROSS RECESSED PAN HEAD SCREW
18	1	RM-06700-27	TRANSFORMER COVER; REAR
19	26	FLOOR STOCK	#8-32 X 1/4 HEX SOCKET BHCS
20	1	RM-05700-26	TRANSFORMER COVER; TOP
21	4	EL-05700-27	TRANSFORMER KNOB
22	24	FLOOR STOCK	1/4-20 X 3/4 HEX CAP SCREW
23	26	FLOOR STOCK	1/4 LOCK WASHER
24	10	FLOOR STOCK	1/4 PLAIN WASHER
25	1	EL-05230-02	STRAIGHT CONDUIT CONNECTOR
26	1	YS-1	Y-STRAINER ASSEMBLY "A" SIDE (PAGE 59)
27	1	YS-2	Y-STRAINER ASSEMBLY "R" SIDE (PAGE 59)
28	1	CL-06001-9	HEATER COVER; FRONT
29	1	CL-06001-07	HEATER COVER; TOP
30	1	CL-06001-08	HEATER COVER; BACK
31	1	RM-05201-2	CONSOLE ENCLOSURE; TOP
32	1	RM-05201-1A	CONSOLE HINGE
33	2	EL-05220-01	CONSOLE KNOBS
34	2	EL-00020	REVERSING SWITCH
34a	4		NOTCHED NUT
35	1	MQ-01005A_PMCA	REVERSING SWITCH; MTG PLATE (PMCA)
36	4	FLOOR STOCK	5/16-18 X 1/2 HEX CAP SCREW
37	2	FLOOR STOCK	1/4-20 X 1-1/4 HEX CAP SCREW
38	4	FLOOR STOCK	5/16-18 X 1 HEX CAP SCREW
39	20	FLOOR STOCK	5/16 LOCK WASHER
40	1	EL-53-2	DIRECTIONAL VALVE; SUB PLATE
41	1	EL-53-1	DIRECTIONAL VALVE
42	1	EL-000P13	STRAIN RELIEF
43	1	EL-05235	THERMOCOUPLE HARNESS; 24"
44	1	NE-06001	AIR REGULATOR
45	4	NE-06010	QUICK LOCK TUBE FITTING
46	1	NE-06007	AIR PRESSURE GUAGE
47	1	NE-06008	AIR/WATER SEPARATOR
48	1	RA-06002	3/8 PIPE MALE X 3/8 PIPE FEMALE
49	2	RA-06004	3/8 NPT NIPPLE
50	1	RA-06005	3/8 PIPE SWIVEL ADAPTER



PMCA-20 Manual

51	1	MQ-01008A	LUBE BOTTLE BRACKET
52	1	MQ-01009-01A	LUBE BOTTLE
53	1	HI-00010	DRIP PAN
54	1	HI-05069	ELBOW; 1/8 X 90 DEGREE
55	1	HI-05094	3/8 NPT RUNNING TEE
56	1	RM-PAR216P64	PARKER BRASS NIPPLE
57	1	RM-PAR-2203P4	PARKER BRASS TEE
58	1	RM-PAR216P4	PARKER BRASS NIPPLE
59	1	HI-05076	1/4 NPT CAP
60	1	EL-00088-01A	HEYCO SR INCOMING POWER
61	2	FLOOR STOCK	#10-32 X 1-1/2 HEX SHCS
62	4	FLOOR STOCK	#8-32 X 1/2 HEX SOCKET BHCS
63	1	MQ-01006A	REVERSING SWITCH; COVER



PMCA-20 Manual

Lube Bottle Components

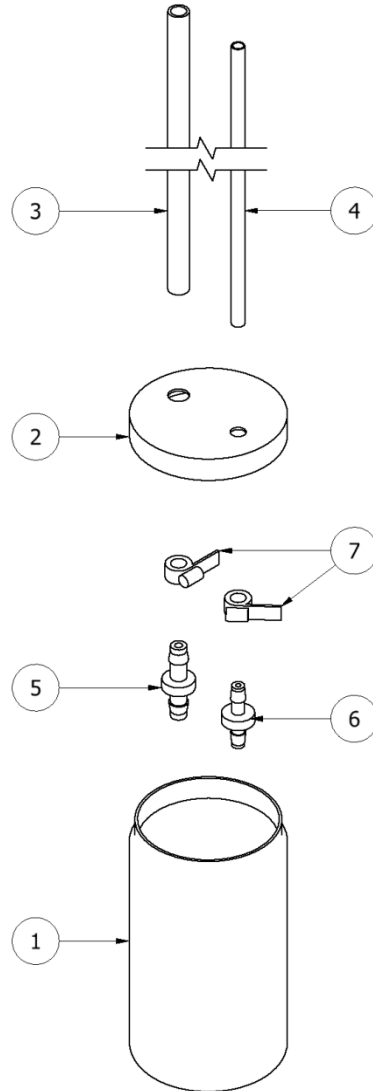

LUBE BOTTLE ASSEMBLY			
ITEM	QTY	PART NUMBER	DESCRIPTION
1	1	MQ-01009-01A	LUBE BOTTLE
2	1	MQ-01009-02A	LUBE BOTTLE LID
3	1	MA-00024A	1/2" X 3' PLASTIC TUBING RETURN
4	1	MA-00025A	3/8" X 3' PLASTIC TUBING SUPPLY
5	1	RA-00068A	CHECK VALVE
6	2	RA-06008	CHECK VALVE
7	2	TN-04196	HOSE CLAMP
-	1	GP-00960-1-GAL	PUMP LUBE GALLON (NOT SHOWN)
-	1	GP-00960-1-QRT	PUMP LUBE QUART (NOT SHOWN)

Hoses

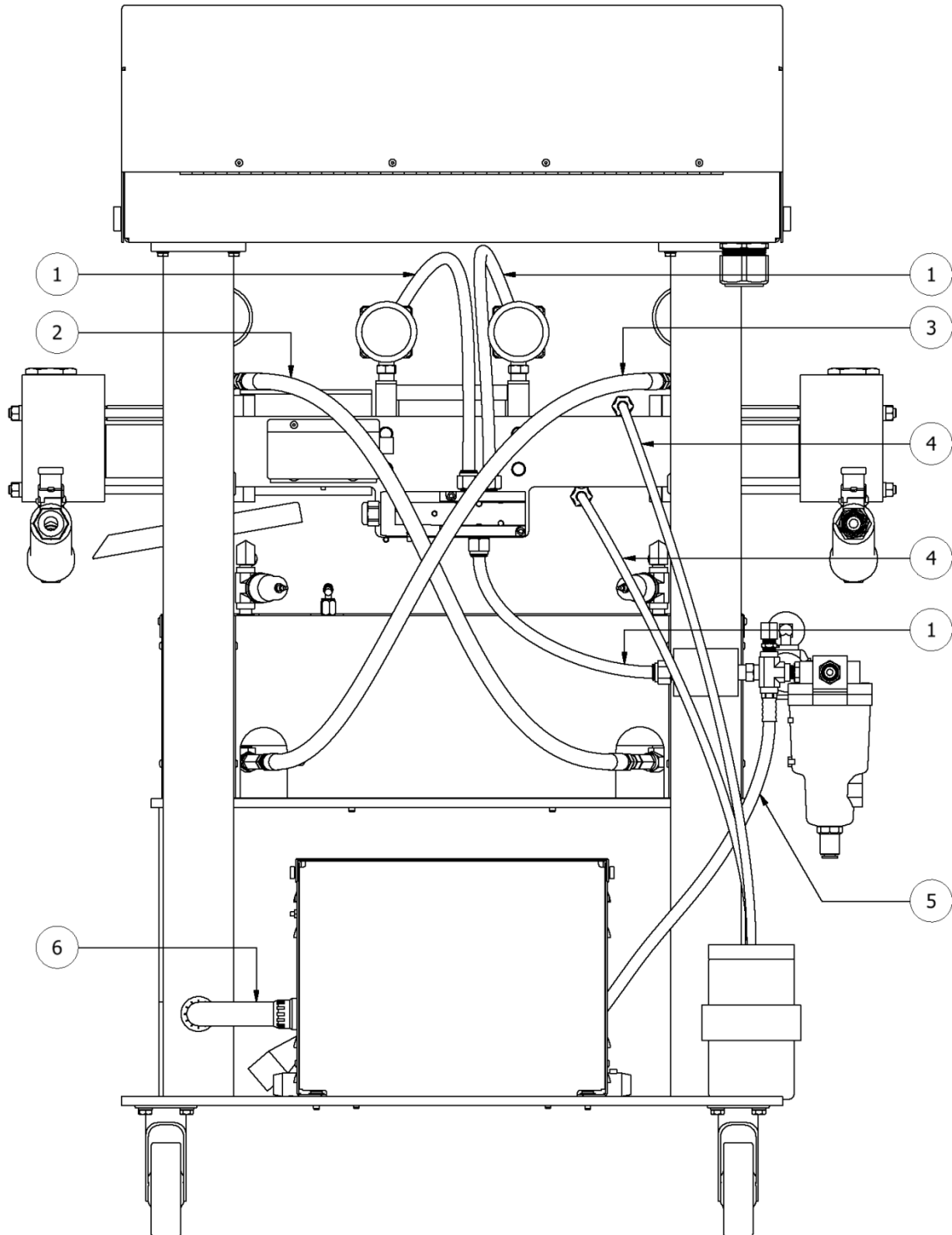



PMCA-20 Manual

HOSES			
ITEM	QTY	PART NUMBER	DESCRIPTION
1	3 FT	RM-E-87-0101	POLY TUBING
2	1	HI-05066	FLUID HOSE; 3/8 X 32"
3	1	HI-05056	FLUID HOSE; 3/8 X 3'
4	2	MA-00025A	LUBE HOSE; 3/8 X 18"
	2	RA-00068A	CHECK VALVE
5	1	MA-00049A	AIR HOSE; 1/4 X 3'
6	3 FT	EL-05230-01	FLEX CONDUIT; 3/4



PMCA-20 Manual

TECHNICAL SERVICE BULLETIN

PRODUCT IMPROVEMENT NOTICE

June, 2013

REF: PMC AIR MACHINES

All PMC air driven machines manufactured after June 10th, 2013 have been fitted with an air manifold that will require only one air line to the machine. The manifold has provisions to supply air to the transfer pumps and the spray gun. The manifold will include a 3' air hose that will attach to the airline on the first section of heated hose coming off the machine. The manifold also includes a fitting to connect the air line harness for the transfer pumps.

The new air line harness is part number MA-00037A and is included with the transfer pump package GHO-A-PKG. The 3' air hose that will attach to the airline on the first section of heated hose is part number MA-00049A.



PMCA-20 Manual

PA, PAX, F-16, P-30 AIR MANIFOLD



NOTE:

- 1- MA-00049A is included with the machine.
- 2- MA-00037A is included in the GHO-A-PKG transfer pump package.



PMCA-20 Manual

PMCA AIR MANIFOLD

REMOVE SAFETY CAP AND CONNECT THE TRANSFER PUMP AIR LINE (MA-00037A)

INLET AIR 90-120 PSI

AIR HOSE TO HEATED HOSE (MA-00049A)

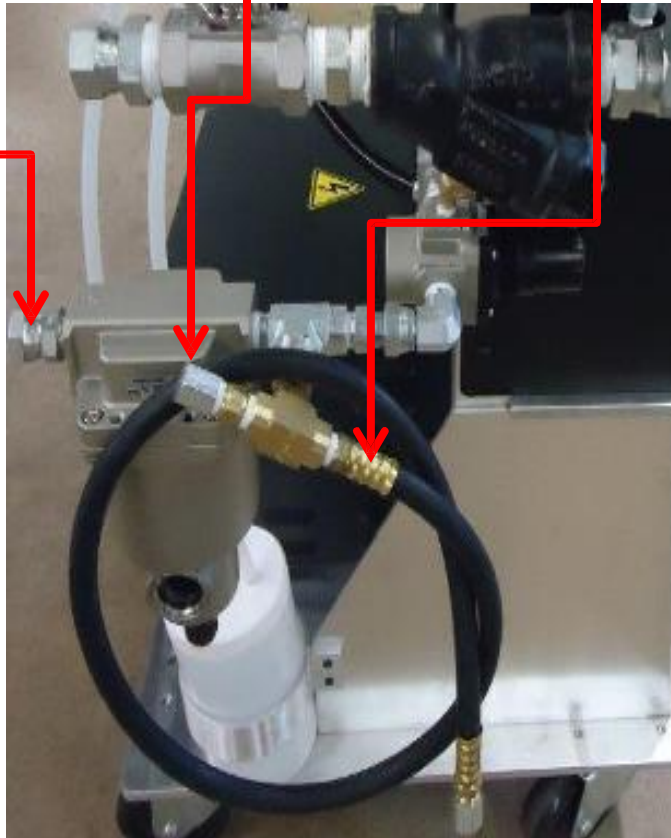

NOTE:

- 1- MA-00049A is included with the machine.
- 2- MA-00037A is included in the GHO-A-PKG transfer pump package.



PMCA-20 Manual

MANUAL REVISIONS

REVISION	DATE	CHANGES	APPROVED
1.0	20-Feb-15	Updated illustrations and tables	Vadams
2.0	01-Jan-16	Updated TSU from old style to new style` Updated all pumps to reflect new seals	ScottS