

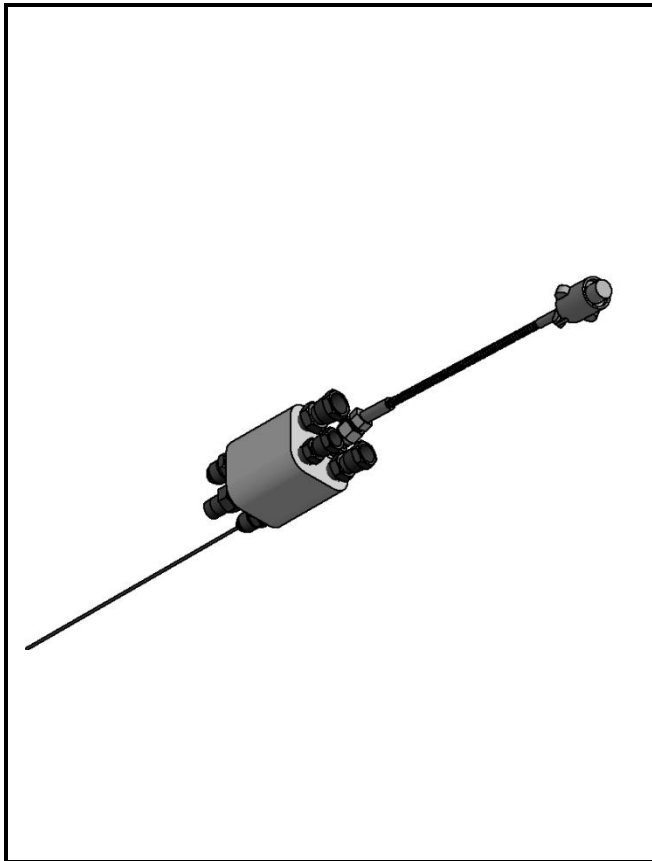

**POLYURETHANE
MACHINERY
CORPORATION**



EL-51A-4 TEMPERATURE SENSING UNIT

**Manual
Ref. # MN-04016**

**REVISION 1.0
September 1, 2015**

Polyurethane Machinery Corp.

Corporate: 1 Komo Dr, Lakewood, NJ 08701

Manufacturing: 2 Komo Dr, Lakewood, NJ
08701

Phone: 732-415-4400

Fax: 732-364-4025

URL: <http://www.polymac-usa.com>



Before using the TSU, carefully read all the technical and safety documentation included in this manual. Pay special attention to the information in order to know and understand the operation and the conditions of use of the TSU. All of the information is aimed at improving user safety and avoiding possible failures from the incorrect use of the TSU.

TABLE OF CONTENTS

WARRANTY.....	1
SAFETY AND HANDLING.....	3
CHARACTERISTICS	5
TECHNICAL SPECIFICATIONS.....	5
DESCRIPTION	6
INSTALLATION	7
TROUBLESHOOTING	8
PART IDENTIFICATION	10
MANUAL REVISIONS	11



WARRANTY

Polyurethane Machinery Corporation (hereinafter “PMC”) provides this **LIMITED WARRANTY** (hereinafter “Warranty”) to the original purchaser (hereinafter “Customer”) covering this equipment and the original PMC manufactured accessories delivered with the equipment (hereinafter “Product”) against defects in material or workmanship of the Product (hereinafter “Defect” or “Defective”) for a period of one (1) year from the date of first purchase as shown on the original PMC invoice (hereinafter “Warranty Period”).

If during the Warranty Period under normal use, the Product is suspected by Customer to be Defective in material or workmanship, it is Customer’s responsibility to contact PMC and return the Product to PMC as directed by PMC, freight prepaid. If PMC determines that the Product is Defective and that such Defect is covered by this Warranty, PMC will credit Customer for the reasonable freight charges incurred by Customer in returning the Defective Product to PMC, and PMC (or its authorized agent) will, at PMC’s option, repair or replace the Product, subject to the following:

Original Invoice: The original invoice must be kept as proof of the date of first sale and the Product serial number. The Warranty does not cover any Product if the Original Invoice appears to have been modified or altered, or when the serial number on the Product appears to have been altered or defaced.

Product Maintenance: It is the Customer’s responsibility to maintain the Product properly. See your maintenance schedule and owner’s manual for details. The Warranty does not cover an improperly maintained Product.

Non-PMC Components and Accessories: Non-PMC manufactured components and accessories that are used in the operation of the Product are not covered by this Warranty. Such components and accessories shall be subject to the warranty offered to the Customer, if any, by the original manufacturer of such component or accessory.

Other Warranty Exclusions: The Warranty does not cover any Product that PMC determines has been damaged or fails to operate properly due to misuse, negligence, abuse, carelessness, neglect, or accident. By way of example only, this includes:

- Normal wear and tear.
- Improper or unauthorized installation, repair, alteration, adjustment or modification of the product.
- Use of heating devices, pumping equipment, dispensers, or other parts or accessories with the product that have not been approved or manufactured by PMC.
- Failure to follow the operating instructions and recommendations provided by PMC.
- Cosmetic damage.
- Fire, flood, “acts of God,” or other contingencies beyond the control of PMC.

THE WARRANTY DESCRIBED HEREIN IS THE EXCLUSIVE REMEDY FOR THE CUSTOMER AND IS IN LIEU OF ALL OTHER WARRANTIES, EXPRESS, IMPLIED, STATUTORY OR OTHERWISE, AND THE IMPLIED WARRANTIES OF MERCHANTABILITY AND FITNESS FOR A PARTICULAR PURPOSE AND ALL OTHER WARRANTIES ARE HEREBY DISCLAIMED. TO THE FULLEST EXTENT PERMITTED BY LAW, PMC SHALL NOT BE RESPONSIBLE, WHETHER BASED IN CONTRACT, TORT (INCLUDING, WITHOUT LIMITATION, NEGLIGENCE), WARRANTY OR ANY OTHER LEGAL OR EQUITABLE GROUNDS, FOR ANY CONSEQUENTIAL, INDIRECT, INCIDENTAL, LOST PROFITS, SPECIAL, PUNITIVE OR EXEMPLARY DAMAGES, WHETHER TO PERSON OR PROPERTY, ARISING FROM OR RELATING TO THE PRODUCT, EVEN IF PMC HAS BEEN ADVISED OF THE POSSIBILITY OF SUCH LOSSES OR DAMAGES.

Non-Warranty Service by PMC: If PMC determines that the suspected Defect of the Product is not covered by this Warranty, disposition of the Product will be made pursuant to the terms and conditions of PMC's written estimate on a time and materials basis.

Continuing Warranty for Products Repaired or Replaced under Warranty: Following the repair or replacement of a Product covered by this Warranty, such Product will continue to be subject to the original Warranty for the remainder of original Warranty Period or for three (3) months from the repair or replacement date, whichever is longer.

No Rights Implied: Nothing in the sale, lease or rental of any Product by PMC shall be construed to grant any right, interest or license in or under any patent, trademark, copyright, trade secret or other proprietary right or material owned by anyone; nor does PMC encourage the infringement of same.

Exclusive Warranty: This writing is the final, complete, and exclusive expression of the Warranty covering the Product. Any statements made by PMC, its employees or agents that differ from the terms of this Warranty shall have no effect. It is expressly understood that Customer's acceptance of this Warranty, by performance or otherwise, is upon and subject solely to the terms and conditions hereof, and any additional or different terms and conditions proposed or expressed by Customer or anyone, whether in writing or otherwise, are null and void unless specifically agreed to in writing by an Officer of PMC.

SAFETY AND HANDLING

This chapter contains important information on the safety, handling, and use of your TSU.



Before using the TSU, carefully read all the technical and safety documentation included in this manual. Pay special attention to the information to know and understand the operation and the conditions of use of the TSU. All of the information is aimed at enhancing User Safety and avoiding possible failures derived from the incorrect use of the TSU.

WARNING! Presents information to alert of a situation that might cause serious injuries if the instructions are not followed.

CAUTION! Presents information that indicates how to avoid damage to the Proportioner or how to avoid a situation that could cause minor injuries.

NOTE! Is relevant information of a procedure being carried out.

Careful study of this manual will enable the operator to know the characteristics of the TSU and the operating procedures. By following the instructions and recommendations contained herein, you will reduce the potential risk of accidents; you will provide a better opportunity for incident-free operation for a longer time, greater output, and the possibility of detecting and resolving problems quickly and simply.

Keep this Operations Manual for future consultation of useful information at all times. If you lose this manual, ask for a new copy from your PMC Distributor or go online and visit our web site at www.polymac-usa.com.

The TSU has been designed and built for the application of polyurea chemical systems, polyurethane foam chemical systems, and some two-component epoxy systems.

Always use liquids and solvents that are compatible with the unit. If in doubt, consult your PMC Distributor.

When working with the TSU, it is recommended that the operator wear suitable clothing and elements of personal protection, including, without limitation, gloves, protective goggles, safety footwear, and face masks. Use breathing equipment when working with the TSU in enclosed spaces or in areas with insufficient ventilation. The introduction and follow-up of safety measures must not be limited to those described in this manual. Before using the TSU, a comprehensive analysis must be made of the risks derived from the products to be dispensed, the type of application, and the working environment.



To prevent possible injury caused by incorrect handling of the raw materials and solvents used in the process, carefully read the Material Safety Data Sheet (MSDS) provided by your supplier.

Deal with the waste caused according to current regulations.

To avoid damage caused by the impact of pressurized fluids, do not open any connection or perform maintenance work on components subject to pressure until the pressure has been completely eliminated.

Use suitable protection when operating, maintaining or being present in the area where the equipment is functioning. This includes, but is not limited to, the use of protective goggles, gloves, shoes and safety clothing and breathing equipment.

The equipment includes components that reach high temperatures and can cause burns. Hot parts of the equipment must not be handled or touched until they have cooled completely.

To prevent serious injury through crushing or amputation, do not work with the equipment without the safety guards installed on the moving parts. Make sure that all the safety guards are correctly reinstalled at the end of the repair or maintenance work of the equipment.

CHARACTERISTICS

- Accurate and precise
- Compact design
- Easy to install
- Low maintenance

TECHNICAL SPECIFICATIONS

Thermocouple Type _____ Type E
 Temperature Range _____ 0 to 1000 °F (-18 to 540 °C)
 "A" Side Fittings _____ -5 JIC
 "R" Side Fittings _____ -6 JIC
 Air Fittings _____ 1/4" NPT

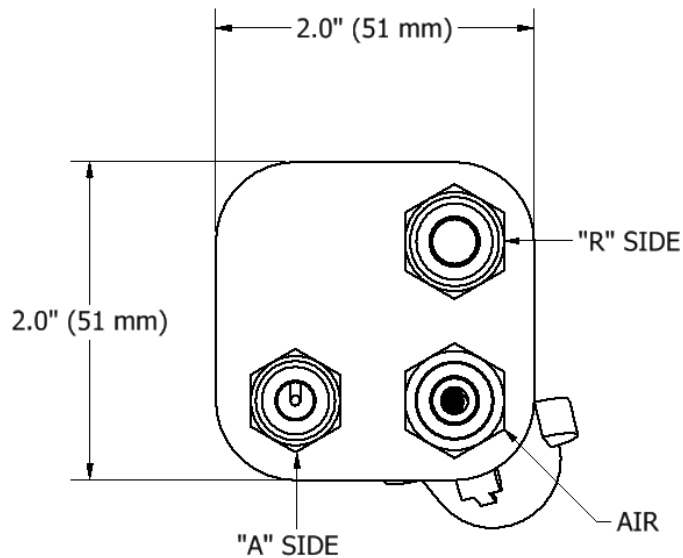
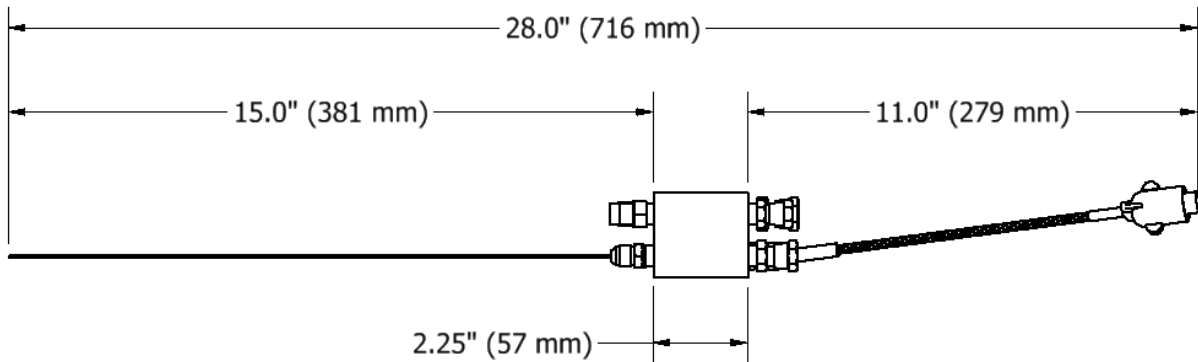

DESCRIPTION

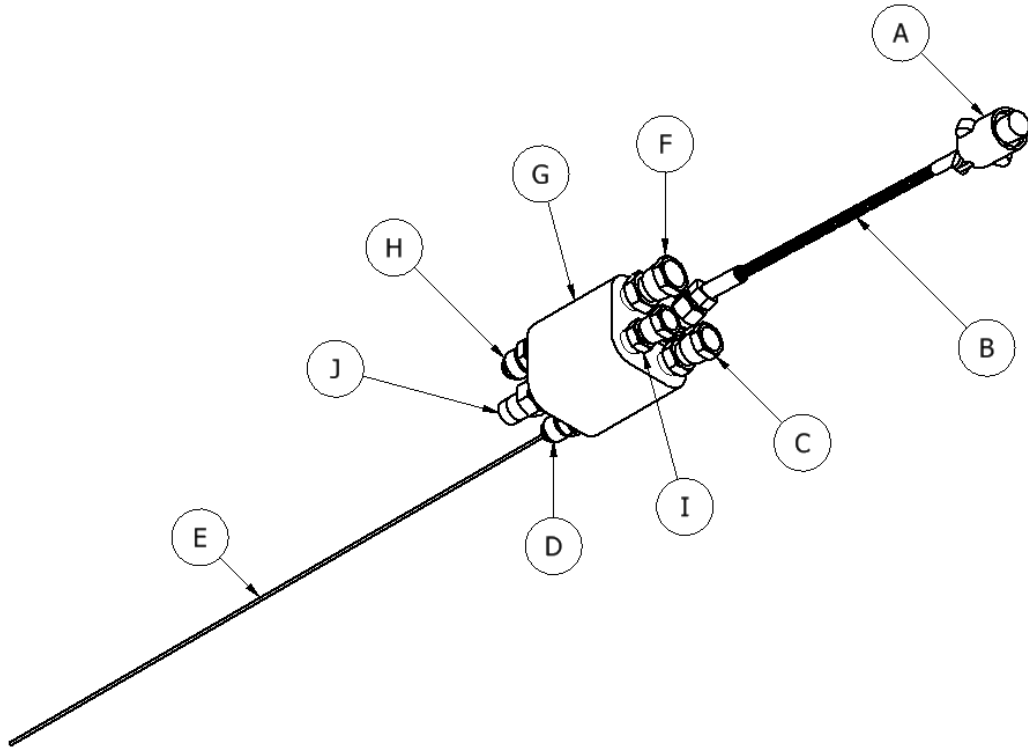

- A. Thermocouple Connector**
- B. Flexible Metal Conduit**
- C. "A" Side Inlet Fitting**
- D. "A" Side Outlet Fitting**
- E. Sensing Wire**
- F. "R" Side Inlet Fitting**
- G. TSU Body**
- H. "R" Side Outlet Fitting**
- I. Air Inlet Fitting**
- J. Air Outlet Fitting**

INSTALLATION

CAUTION! Connecting the TSU between the first and second section of Heated Hose results in the TSU sensing the material temperature exiting the Heater and not the inside of the Heated Hose near the Spray Gun.

CAUTION! To protect the TSU sensor, pay special attention not to kink or excessively bend the Heated Hoses. Do not coil the Heated Hoses with a diameter of less than 4 feet (1.22 meters).

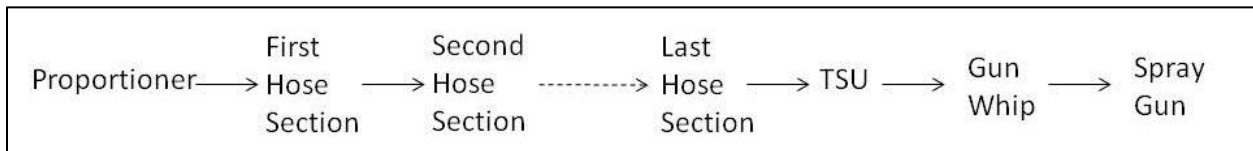

*Recommended order of connections

1. It is recommended that the TSU be installed between the **last section of Heated Hose** and the **Gun Whip**.
2. Before fastening all hoses, install the insulation (not shown) onto the hoses.
3. Carefully straighten the sensing wire and insert it into the Iso (A) Heated Hose
4. Tighten all fluid fittings with appropriate sized open-end wrenches.
5. Secure the thermocouple connectors
6. Slide the insulation over the TSU.

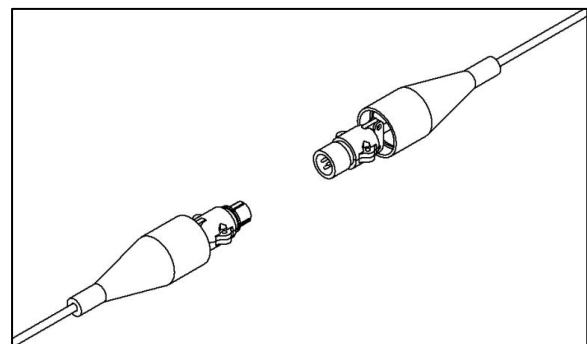
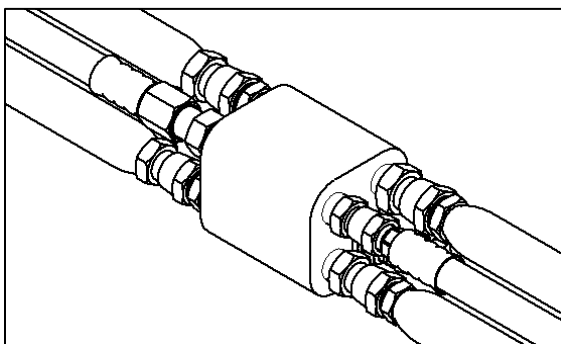
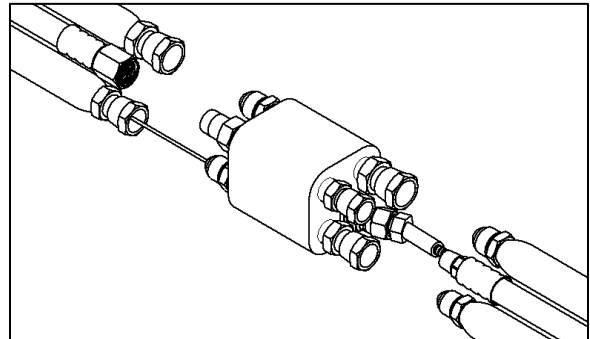

TROUBLESHOOTING

This chapter contains information on possible faults that may interrupt the operation of the TSU. The information provided will serve as a guideline to detect and resolve problems. In any case, feel free to contact your authorized PMC Distributor, where a qualified technician will advise you.

CAUTION! All repairs performed by unqualified personnel or the use of spares other than originals may cause damage to the unit and put the operator at risk.



To prevent possible injury caused by incorrect handling of the raw materials and solvents used in the process, carefully read the safety data sheet provided by your supplier.

Deal with the waste caused according to current regulations.



To avoid damage caused by the impact of pressurized fluids, do not open any connection or perform maintenance work on components subject to pressure until the pressure has been completely eliminated.



Use suitable protection when operating, maintaining or being present in the area where the equipment is functioning. This includes, but is not limited to, the use of protective goggles, gloves, shoes and safety clothing and breathing equipment.



The equipment includes components that reach high temperatures and can cause burns. Hot parts of the equipment must not be handled or touched until they have cooled completely.



To prevent serious injury through crushing or amputation, do not work with the equipment without the safety guards installed on the moving parts. Make sure that all the safety guards are correctly reinstalled at the end of the repair or maintenance work of the equipment.

PROBLEM

Hose does not heat and the display on the controller shows a flashing error message: “SbEr” on the Eaton controller or “EEEE” on the Auber controller.

SOLUTIONS

1. Check the thermocouple terminals (TC+ and TC-) on the heater controller for loose wires and improper connections. There should be a purple wire connected to the TC+ terminal (terminal 9 for Eaton controllers) and a red wire connected to the TC- terminal (terminal 10 for Eaton Controllers).

If connections are secure, move to the next step.

2. Remove the transformer cover and ensure the thermocouple wires are secure to the harness going up to the controller.

If connections are secure, move to the next step.

3. Disconnect the wire from the TSU and connect it directly to the thermocouple harness coming out of the hose transformer.

If the controller still shows the error code, replace the hose thermocouple.

If the error code goes away and temperature is now shown on the display of the controller, then all the TSU harnesses from the TSU to the transformer need to be checked for loose connectors or one or more of the harnesses are defective.

PART IDENTIFICATION

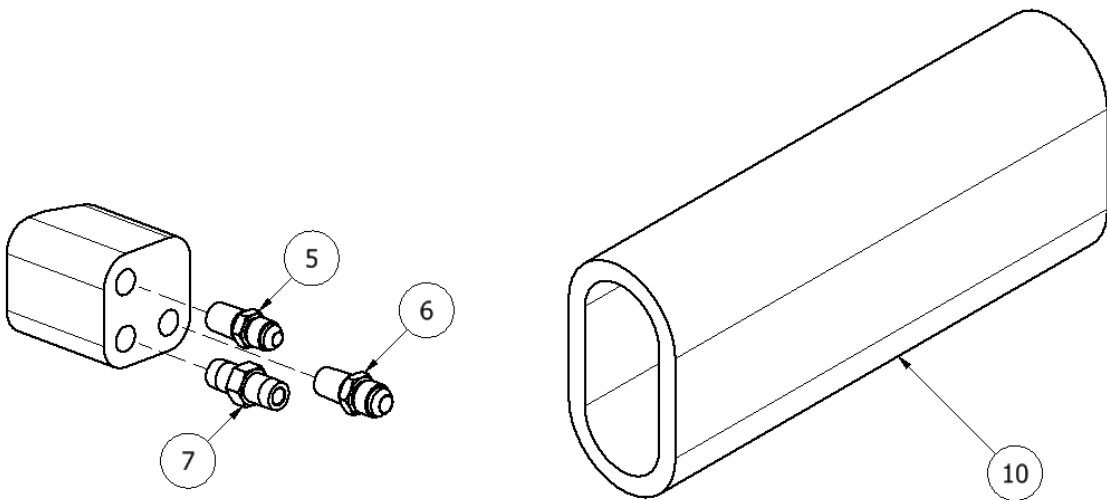
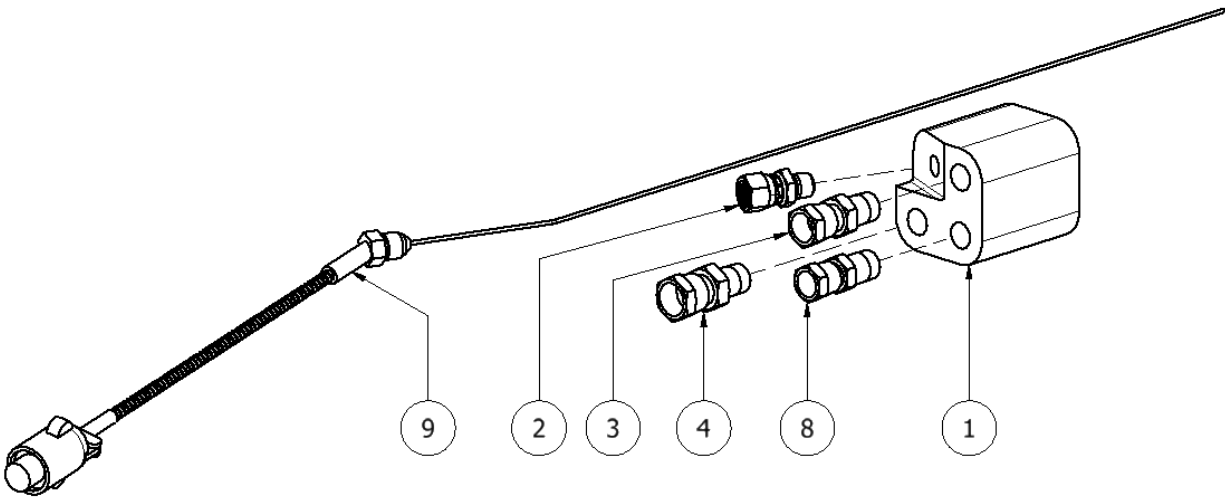

EL-51A-4			
ITEM	QTY	PART NUMBER	DESCRIPTION
1	1	EL-00051A-9	TSU WITH AIR
2	1	EL-00051A-3	1/8 X #4 JIC FEM SWIVEL FTG
3	1	EL-00051A-7	1/4 X #5 JIC FEMALE SWIVEL FTG
4	1	EL-00051A-5	1/4 X #6 JIC FEMALE SWIVEL FTG
5	1	EL-00051A-4	1/4 X #5 JIC MALE FTG
6	1	EL-00051A-6	1/4 X #6 JIC MALE FTG
7	1	GP-00100-1	1/4 PIPE NIPPLE
8	1	EL-00051A-10	1/4 MNPT X 1/4 FNPT SWIVEL
9	1	EL-51A-2	FLEX THERMOCOUPLE
10	1	EL-00051A-8	INSULATION

MANUAL REVISIONS

Revision	Date	Changes	Approved
1.0	01-SEP-2015	Initial release of EL-51A-4 Manual	Vadams